



RoHS compliant  
CL-Q28-LR-SL  
100G QSFP28 LR Optical Transceiver  
Hot Pluggable Dual Single Lambda, SMF, 1310 nm, 10 km, LC, DOM

### Features

- IEEE 100GBASE-LR compliant
- 100GE Single Protocol (103.125Gb/s)
- CAUI-4 compliant - 4x25.78Gb/s
- 100GAUI-4 compliant – 4x26.562Gb/s
- RS-FEC(544,514) FEC coder/decoder function
- Power Consumption 3.5W max
- Operating case temperature -5 to 70°C
- Single cooled 100Gb/s 1310nm EML
- Single PIN PD + low-power TIA
- SFF-8636 management interface

### Applications

- Data Center 100GE 10km SMF links
- 4:1 breakout with 100G-4xFR
- Switch/Router interconnections

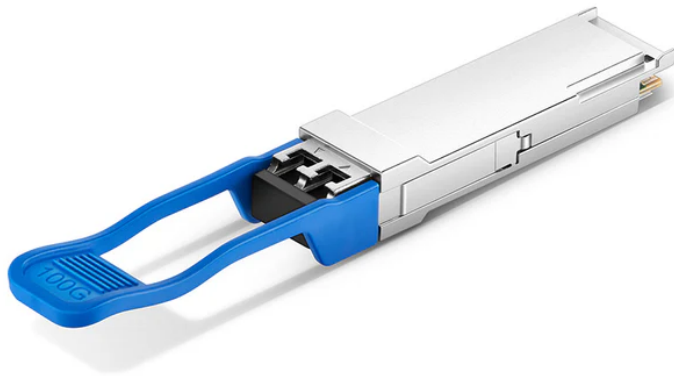

### Ordering Information

PART NUMBER	INPUT/OUTPUT	SIGNAL DETECT	VOLTAGE	TEMPERATURE
CL-Q28-LR-SL	AC/AC	TTL	3.3V	-5°C to 70 °C
CL-Q28-LR-SLi	AC/AC	TTL	3.3V	-40°C to 85 °C



RoHS compliant  
CL-Q28-LR-SL  
100G QSFP28 LR Optical Transceiver  
Hot Pluggable Dual Single Lambda, SMF, 1310 nm, 10 km, LC, DOM

## I. Absolute Maximum Ratings

Parameter	Symbol	Min.	Max.	Unit	Remarks
Supply Voltage	Vcc	0	+3.6	V	+3.3 V
Storage Temperature		-40	85	°C	
Optical Receiver Input		-	+5.5	dBm	Average

## II. Operating Environment

Parameter	Symbol	Min.	Typ.	Max.	Unit	Remarks
Supply Voltage	Vcc	3.135	3.3	3.465	V	
Supply Voltage Noise Tolerance	PSNR	-	-	66	mV	10 Hz –10 MHz
Power Consumption		-	-	3.5	W	Target
Supply Current		--	-	1010.1	mA	Steady state
Case Temperature	TC	0	25	70	°C	

## III. Optical Characteristics

Description	Value	Unit	Notes
<b>Transmitter</b>			
PAM4 Signaling rate (range)	53.125 ± 100 ppm	GBd	
Lane wavelengths (range)	1304.5- 1317.5	nm	
Side-mode suppression ratio (SMSR), (min)	30	dB	
Average launch power (max)	4.8	dBm	
Average launch power (min)	-1.9	dBm	1
Outer Optical Modulation Amplitude (OMA <sub>outer</sub> ) (max)	5	dBm	
Outer Optical Modulation Amplitude (OMA <sub>outer</sub> ) (min) for TDECQ <1.4 dB	1.1	dBm	
Outer Optical Modulation Amplitude (OMA <sub>outer</sub> ) (min) for 1.4 dB	-0.3 + TDECQ	dBm	



**RoHS compliant**  
**CL-Q28-LR-SL**  
**100G QSFP28 LR Optical Transceiver**  
**Hot Pluggable Dual Single Lambda, SMF, 1310 nm, 10 km, LC, DOM**

$\leq TDECQ \leq 3.4$ dB			
Transmitter and dispersion penalty Eye Closure for PAM4 (TDECQ), (max)	3.4	dB	
$ TDECQ - TECQ $ (max)	3.4	dB	
Transmitter eye closure for PAM4 (TECQ) (max)	3.4	dB	
$ TDECQ - TECQ $ (max)	2.5	dB	
Over/under-shoot (max)	22	%	
Transmitter power excursion (max)	2.8	dBm	
Average launch power of OFF transmitter (max)	-15	dBm	
Extinction ratio (min)	3.5	dB	
Optical return loss tolerance (max)	15.6	dB	
Transmitter reflectance <sup>2</sup> (max)	-26	dB	2
Transmitter transition time (max)	17	ps	
RIN <sub>15.5</sub> OMA (max)	-136	dB/Hz	
<b>Receiver</b>			
PAM4 Signaling rate (range)	53.125 ± 100 ppm	GBd	
Lane wavelengths (range)	1304.5 to 1317.5	Nm	
Damage threshold (min)	5.8	dBm	3
Average receive power (max)	4.8	dBm	
Average receive power (min)	-8.2	dBm	4
Receive power (OMA <sub>outer</sub> ) (max)	5	dBm	
Receiver reflectance (max)	-26	dB	
Receiver sensitivity (OMA <sub>outer</sub> ) (max)	-6.1 TECQ-7.1	dBm	
Stressed receiver sensitivity (OMA <sub>outer</sub> ) (max)	-4.1		5
<b>Conditions of stressed receiver sensitivity test</b>			6
Stressed eye closure for PAM4 (SECQ)	3.4	dB	
SECQ - 10*log <sub>10</sub> (Ceq) (max)	-	dB	7



**RoHS compliant**  
**CL-Q28-LR-SL**  
**100G QSFP28 LR Optical Transceiver**  
**Hot Pluggable Dual Single Lambda, SMF, 1310 nm, 10 km, LC, DOM**

Notes:

1. Average launch power, each lane (min) is informative and not the principal indicator of signal strength. A transmitter with launch power below this value cannot be compliant; however, a value above this does not ensure compliance.
2. Transmitter reflectance is defined looking into the transmitter.
3. The receiver shall be able to tolerate, without damage, continuous exposure to an optical signal having this average power level
4. Average receive power, each lane (min) is informative and not the principal indicator of signal strength. A received power below this value cannot be compliant; however, a value above this does not ensure compliance.
5. Measured with conformance test signal at TP3 (see 100G Lambda MSA 100G-FR - "Technical Specification, Rev. 2.0 clause 3.11) for the BER specified in IEEE Std 802.3cd clause 140.1.1.
6. These test conditions are for measuring stressed receiver sensitivity. They are not characteristics of the receiver.
7. Ceq is a coefficient defined in IEEE Std 802.3-2018 clause 121.8.5.3 which accounts for reference equalizer noise enhancement.

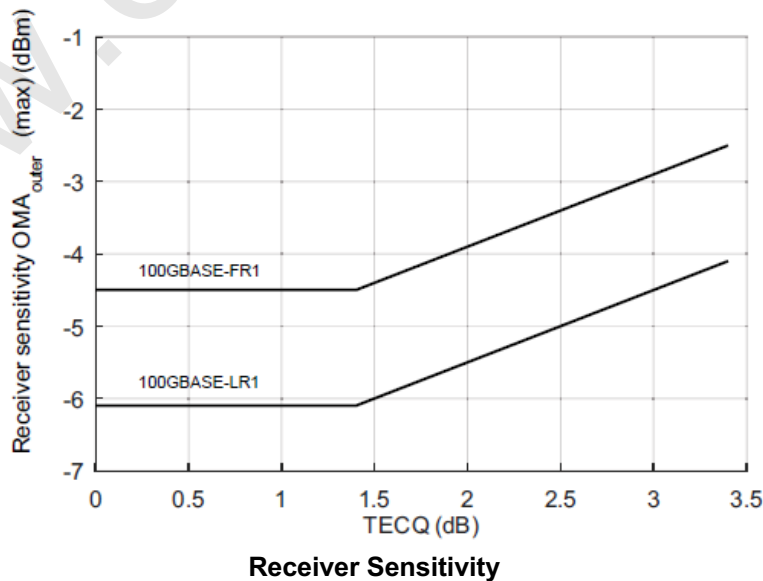
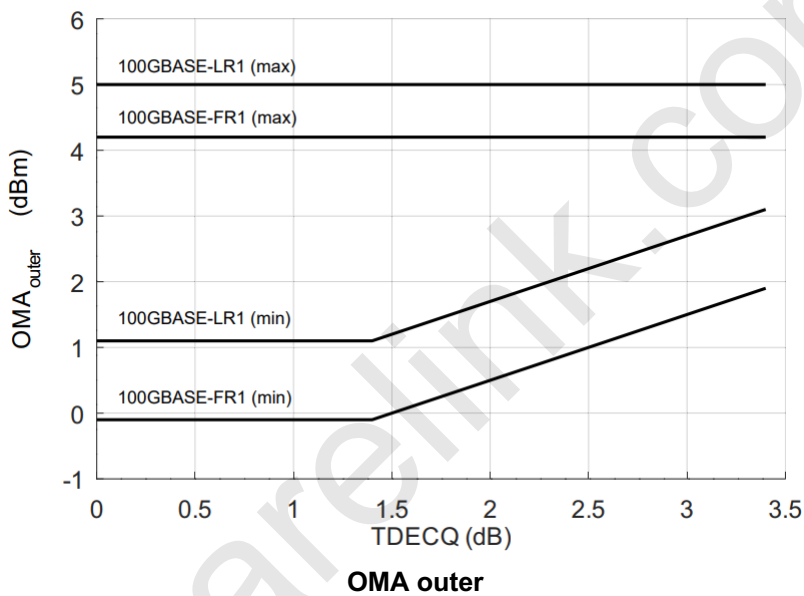



RoHS compliant  
CL-Q28-LR-SL  
100G QSFP28 LR Optical Transceiver  
Hot Pluggable Dual Single Lambda, SMF, 1310 nm, 10 km, LC, DOM

#### IV. RX\_LOS Characteristics

Parameter	Symbol	Min.	Typ.	Max.	Unit	Remarks
Receiver Loss of Signal Indicator Assert Level	RX_LOS	-30	-	-7.5	dBm	Average power
Receiver Loss of Signal Indicator De-assert Level	RX_LOS	-	-	-7	dBm	Average power
Hysteresis	RX_LOS	0.5	-	-	dB	

#### V. Electrical Characteristics

Parameter	Min.	Typ.	Max.	Unit	Remarks
<b>Transmitter (each lane)</b>					
Differential pk-pk input voltage tolerance (min)	900	-	-	mV	at TP1a
Differential termination mismatch	-	-	10	%	at TP1
Single-ended input voltage tolerance range	-0.4 to 3.3	-	-	V	at TP1a
DC common mode voltage	-350	-	2850	mV	at TP1
<b>Receiver (each lane, at TP4)</b>					
AC Common-mode output voltage (RMS)	-	-	17.5	mV	
Differential output voltage	-	-	900	mV	
Eye width	0.57	-	-	UI	
Eye height, differential	228	-	-	mV	
Vertical eye closure	-	-	5.5	dB	
Differential termination mismatch	-	-	10	%	
Transition time (20% to 80%)	12	-	-	ps	
DC common mode voltage	-350	-	2850	mV	

Notes:

1. Electrical Rx output is squelched for loss of optical input signal.



RoHS compliant  
 CL-Q28-LR-SL  
 100G QSFP28 LR Optical Transceiver  
 Hot Pluggable Dual Single Lambda, SMF, 1310 nm, 10 km, LC, DOM

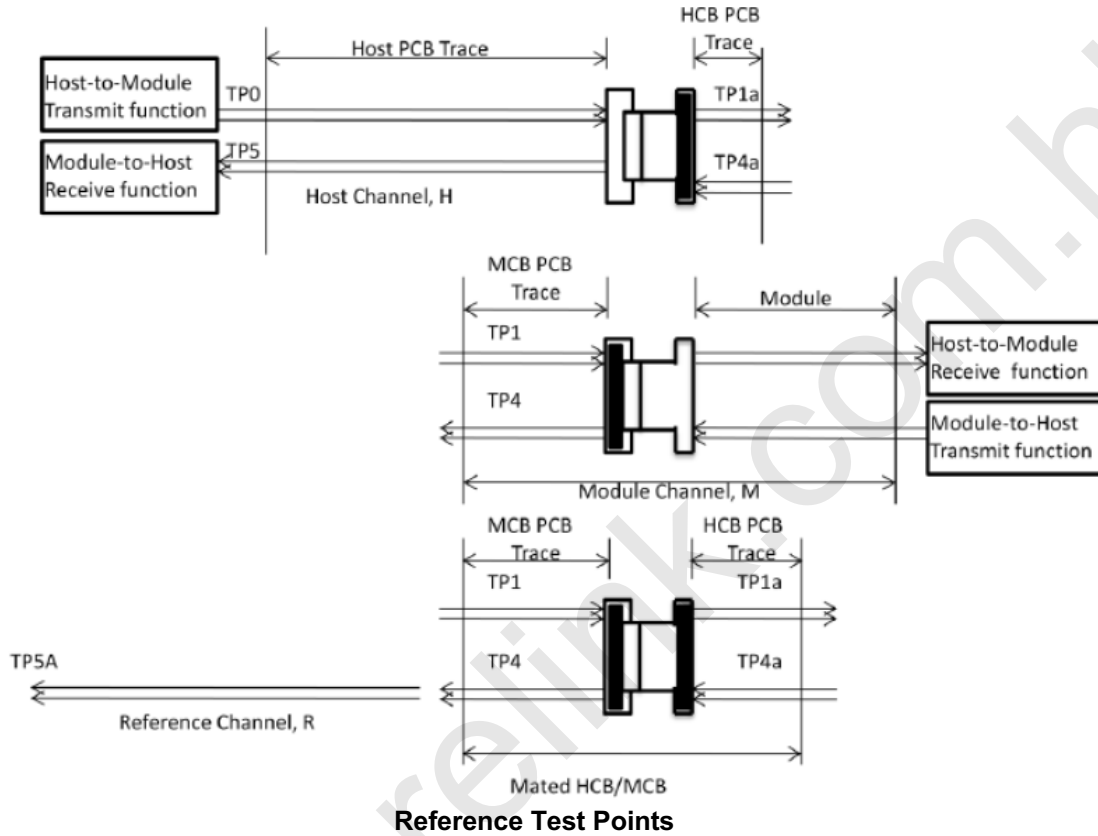

## VI. Pin Diagram

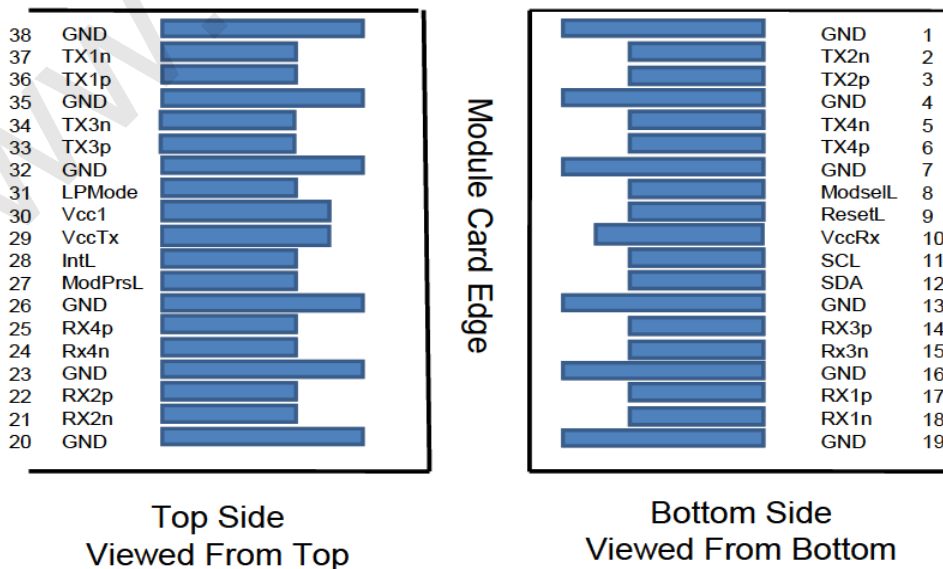



RoHS compliant  
 CL-Q28-LR-SL  
 100G QSFP28 LR Optical Transceiver  
 Hot Pluggable Dual Single Lambda, SMF, 1310 nm, 10 km, LC, DOM

## VII. Pin Descriptions

Pin	Logic	Symbol	Description	Plug Sequence	Notes
1		GND	Ground	1	1
2	CML-I	Tx2n	Transmitter Inverted Data Input	3	
3	CML-I	Tx2p	Transmitter Non-Inverted Data Input	3	
4		GND	Ground	1	1
5	CML-I	Tx4n	Transmitter Inverted Data Input	3	
6	CML-I	Tx4p	Transmitter Non-Inverted Data Input	3	
7		GND	Ground	1	1
8	LVTTL-I	ModSelL	Module Select	3	
9	LVTTL-I	ResetL	Module Reset	3	
10		Vcc Rx	+3.3V Power Supply Receiver	2	2
11	LVC MOS-I/O	SCL	2-wire serial interface clock	3	
12	LVC MOS-I/O	SDA	2-wire serial interface data	3	
13		GND	Ground	1	1
14	CML-O	Rx3p	Receiver Non-Inverted Data Output	3	
15	CML-O	Rx3n	Receiver Inverted Data Output	3	
16		GND	Ground	1	1
17	CML-O	Rx1p	Receiver Non-Inverted Data Output	3	
18	CML-O	Rx1n	Receiver Inverted Data Output	3	
19		GND	Ground	1	1
20		GND	Ground	1	1
21	CML-O	Rx2n	Receiver Inverted Data Output	3	
22	CML-O	Rx2p	Receiver Non-Inverted Data Output	3	
23		GND	Ground	1	1
24	CML-O	Rx4n	Receiver Inverted Data Output	3	
25	CML-O	Rx4p	Receiver Non-Inverted Data Output	3	
26		GND	Ground	1	1
27	LVTTL-O	ModPrsL	Module Present	3	
28	LVTTL-O	IntL	Interrupt	3	
29		Vcc Tx	+3.3V Power supply transmitter	2	2
30		Vcc1	+3.3V Power supply	2	2
31	LVTTL-I	LPMode	Low Power Mode	3	
32		GND	Ground	1	1
33	CML-I	Tx3p	Transmitter Non-Inverted Data Input	3	
34	CML-I	Tx3n	Transmitter Inverted Data Input	3	
35		GND	Ground	1	1
36	CML-I	Tx1p	Transmitter Non-Inverted Data Input	3	
37	CML-I	Tx1n	Transmitter Inverted Data Input	3	
38		GND	Ground	1	1
<p>Note 1: GND is the symbol for signal and supply (power) common for the module. All are common within the module and all module voltages are referenced to this potential unless otherwise noted. Connect these directly to the host board signal-common ground plane.</p>					
<p>Note 2: Vcc Rx, Vcc1 and Vcc Tx shall be applied concurrently. Requirements defined for the host side of the Host Edge Card Connector are listed in Table 5-6. Vcc Rx Vcc1 and Vcc Tx may be internally connected within the module in any combination. The connector pins are each rated for a maximum current of 1000 mA.</p>					



RoHS compliant  
CL-Q28-LR-SL  
100G QSFP28 LR Optical Transceiver  
Hot Pluggable Dual Single Lambda, SMF, 1310 nm, 10 km, LC, DOM

### VIII. Mechanical Specifications(Unit: mm)

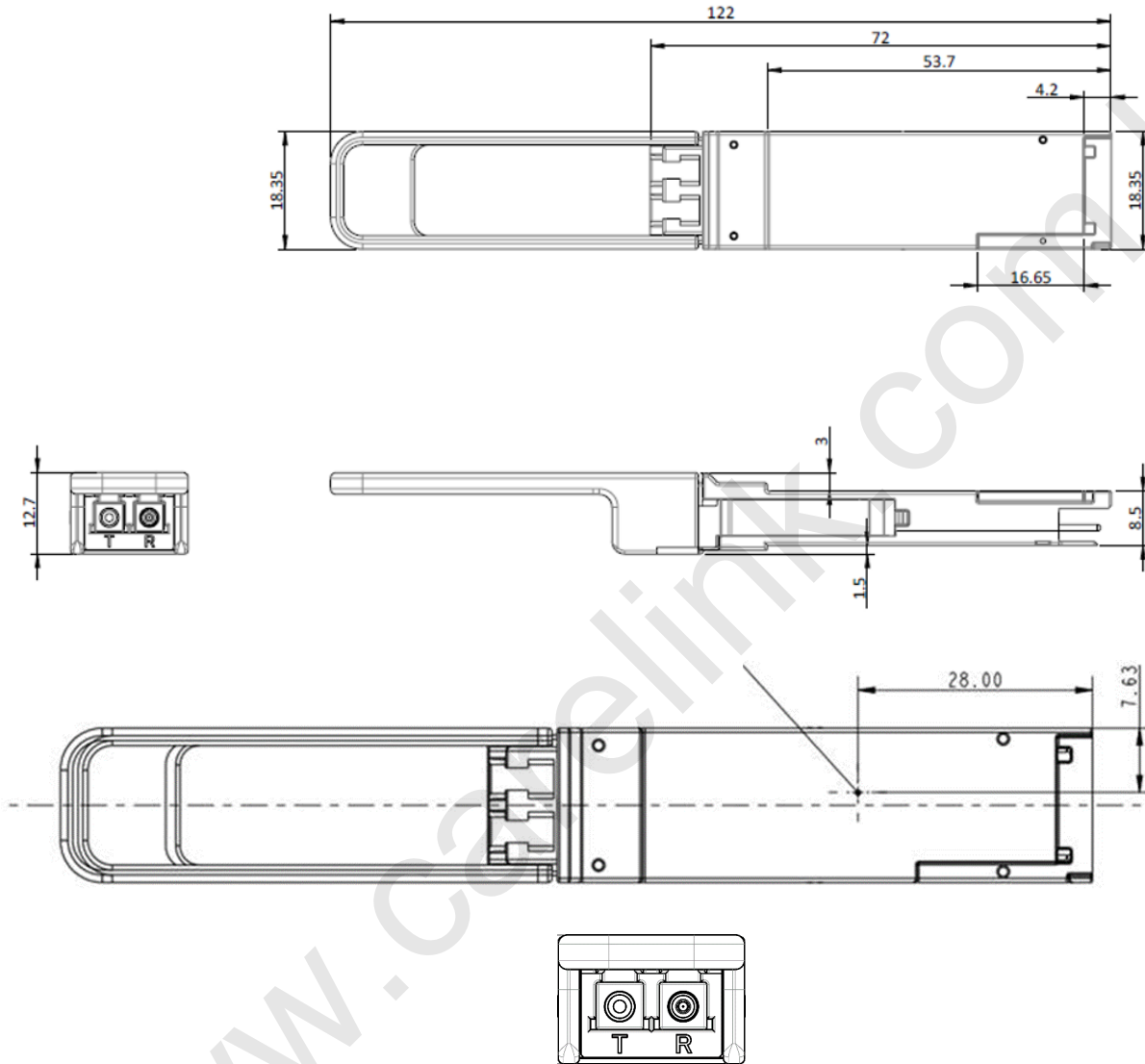

#### Notice:

Carelink reserves the right to make changes to or discontinue any optical link product or service identified in this publication, without notice, in order to improve design and/or performance. Applications that are described herein for any of the optical link products are for illustrative purposes only. Carelink makes no representation or warranty that such applications will be suitable for the specified use without further testing or modification.