



**CL-Q28-LR-10-27**  
**Single-Mode QSFP28 100G BIDI 10km Transceiver**  
**RoHS 6 compliant**



• **Features**

- QSFP28 MSA package with simplex LC connector
- Compliant to 100G Lambda MSA 100G-LR1 Optical Specifications
- Interoperable with IEEE 802.3cu
- Lane signaling rate 53.125GBd with PAM4
- High speed I/O electrical interface
- Two Wire Serial Interface with Digital Diagnostic Monitoring
- Operating case temperature range -5°C to +70°C
- Support KP4 FEC inside the module and KP4 FEC shutdown
- Reaches up to 10km on SMF
- Maximum power consumption 4.5W
- 3.3V power supply voltage
- compliant to RoHS2.0
- Class 1 Laser

**Applications**

- 100 Gigabit Ethernet
- Data Center

PART NUMBER	Monitor	INPUT/OUTPUT	SIGNAL DETECT	TEMPERATURE
CL-Q28-LR-10-27	X	AC/AC	TTL	-5°C to 70 °C
CL-Q28-LR-10-27i	X	AC/AC	TTL	-40°C to 85 °C



**CL-Q28-LR-10-27**  
**Single-Mode QSFP28 100G BIDI 10km Transceiver**  
**RoHS 6 compliant**

### Absolute Maximum Ratings

Parameter	Symbol	Conditions	Min.	Max.	Unit
Storage temperature ( case )	Tstg	-	-40	+85	°C
Relative Humidity	RH	Non-condensing	5	85	%
Supply voltage	VCC		0	3.6	V
Low speed signal voltage range			-0.3	4.0	V
Damage threshold	Pin	Average		5.5	dBm
ESD Sensitivity		-		±500V for RF ±2kV for others	V

### Recommended Operating Conditions

Parameter	Symbol	Min.	Typical	Max.	Unit
Operating Case Temperature	Tcase	-5	-	70	°C
Supply Voltage	VCC	3.135	3.3	3.465	V
Relative Humidity	RH	5	-	85	%
Power Dissipation	PD	-	-	4.5	W
Data Rate (optical)	DRO	-	103.125	106.25	Gbps
Data Rate (Electrical)	DRE	-	26.5625	-	Gbps
Operating Link Distance	LD	-	-	10	Km

### Optical Characteristics

Parameter	Symbol	Condition	Min.	Typ.	Max.	Unit	Note
<b>Transmitter</b>							
Data Rate				103.125	106.25	Gbps	
Data rate variation			-100		+100	ppm	
Lane center wavelength			1264.5	1271	1277.5	nm	
			1324.5	1331	1377.5	nm	



**CL-Q28-LR-10-27**  
**Single-Mode QSFP28 100G BIDI 10km Transceiver**  
**RoHS 6 compliant**

Launch power	Peach		-1.4		4.5	dBm	1 , 2
Optical modulation amplitude	POMA		0.7		4.7	dBm	3
Launch power in OMA minus TDECQ	For ER $\geq$ 4.5dB B For ER $<$ 4.5dB		-0.7 -0.6			dBm	
Transmitter and Dispersion eye closure	TDECQ				3.4	dBm	
Optical Extinction Ratio	ER		3.5			dB	
Side mode Suppression ratio	SMSR		30			dB	
Launch power of OFF Transmitter					-30	dBm	
Relative Intensity Noise	RIN				-136	dB/Hz	
Optical return loss tolerance					15.6	dB	
Transmitter reflectance					-26	dB	4
<b>Receiver</b>							
Data Rate				103.125	106.25	Gbps	
Data rate variation			-100		+100	Ppm	
Lane center wavelength			1324.5	1331	1377.5	nm	
			1264.5	1271	1277.5	nm	
Damage threshold	Rdam		5.5			dBm	5
Average receiver power	Rpow		-7.7		4.5	dBm	6
Receiver power(OMA)	Rovl				4.7	dBm	



**CL-Q28-LR-10-27**  
**Single-Mode QSFP28 100G BIDI 10km Transceiver**  
**RoHS 6 compliant**

Receiver sensitivity (OMA), (max)	SENeach				-6.1	dBm	@BER2.4e-4
Stressed Sensitivity	SRS				-4.1	dBm	8
Receiver reflectance					-26	dB	
LOSS assert	Optical power alarm		-26		-12	dBm	
LOSS de-assert					-10	dBm	
Conditions of stressed receiver sensitivity test:							
Stressed eye closure for PAM4 (SECQ),					3.4	dB	8
SECQ-10*lgCeq					3.4	dB	8

Note1. As the total average launch power limit has to be met, not all of the lanes can operate at the maximum average launch power ,each lane.

Note2. Average launch power, each lane(min) is informative and not the principal indicator of signal strength. A transmitter with launch power below this value can not be compliant: however, a value above this does not ensure compliance.

Note3. Even if the TDECQ<1.4dB for an extinction ratio of >=4.5dB or TDECQ<1.3dB for an extinction ratio of <4.5dB, the OMA outer (min) must exceed this value.

Note4. Transmitter reflectance is defined looking into the transmitter.

Note5. The receiver shall be able to tolerate, without damage, continuous exposure to an optical input signal having this average power level.

Note6. Average receiver power, each lane(min) is informative and not the principal indicator of signal strength. A received power below this value cannot be compliant; however, a value above this does not ensure compliance.

Note7. Measured with conformance test signal at TP3 for the BER specified in 《100G-FR and 100G-LR1

Technical Specifications Rev 2.0》

Note8. These test conditions are for measuring stressed receiver sensitivity. They are not characteristics of the receiver.



**CL-Q28-LR-10-27**  
**Single-Mode QSFP28 100G BIDI 10km Transceiver**  
**RoHS 6 compliant**

**Electrical Specifications**

<b>Transmitter (Module Input)</b>					
<b>Parameter</b>	<b>Symbol</b>	<b>Min.</b>	<b>Typical</b>	<b>Max.</b>	<b>Unit</b>
Input Differential Impedance	Rin	-	100	-	Ohm
Differential termination mismatch (max)	D-mismatch	-	-	10	%
Differential Data Input Amplitude	VIN,P-P	-	-	900	mVp p
LPMode, Reset and ModSelL	VIL	-0.3	-	0.8	V
	VIH	2.0	-	VCC+0.3	V
<b>Receiver (Module Output)</b>					
Output Differential Impedance	Rout	-	100	-	Ohm
Differential termination mismatch (max)	D-mismatch	-	-	10	%
Differential Data Output Amplitude	VOUT,P-P	-	-	900	mVp p
ModPrsL and IntL	VOL	0	-	0.4	V
	VOH	VCC-0.5	-	VCC+0.3	V

**Pin layout**

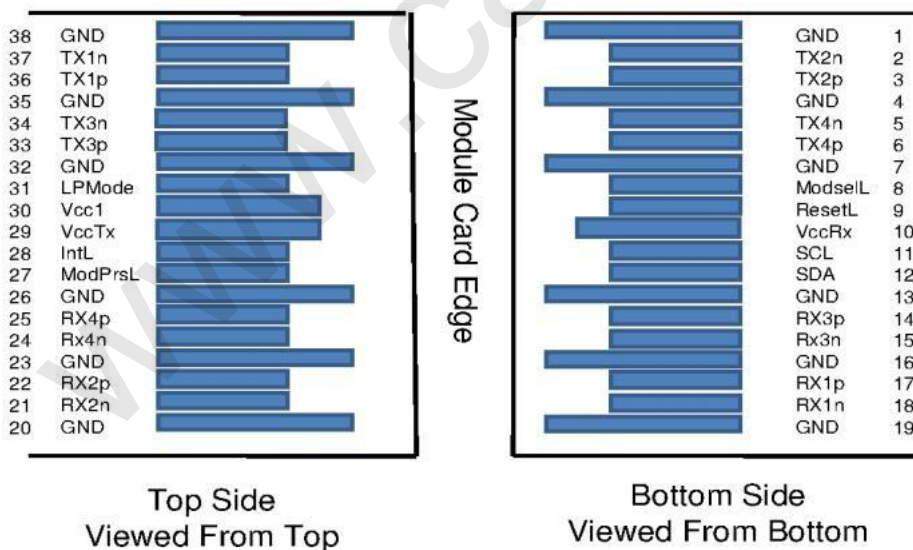

Figure1 Top Side and Bottom Side of QSFP28



**CL-Q28-LR-10-27**  
**Single-Mode QSFP28 100G BIDI 10km Transceiver**  
**RoHS 6 compliant**

## Pin Definitions

Pin no.	Logic	Symbol	Description	Note
1		GND	Ground	1
2	CML-I	Tx2n	Transmitter Inverted Data Input	
3	CML-I	Tx2p	Transmitter Non-Inverted Data Input	
4		GND	Ground	1
5	CML-I	Tx4n	Transmitter Inverted Data Input	
6	CML-I	Tx4p	Transmitter Non-Inverted Data Input	
7		GND	Ground	1
8	LVTLL-I	ModSelL	Module Select	3
9	LVTLL-I	ResetL	Module Reset	4
10		VccRx	+3.3V Power Supply Receiver	2
11	LVC MOS-I/O	SCL	2-Wire Serial Interface Clock	3
12	LVC MOS-I/O	SDA	2-Wire Serial Interface Data	3
13		GND	Ground	1
14	CML-O	Rx3p	Receiver Non-Inverted Data Output	
15	CML-O	Rx3n	Receiver Inverted Data Output	
16		GND	Ground	1
17	CML-O	Rx1p	Receiver Non-Inverted Data Output	
18	CML-O	Rx1n	Receiver Inverted Data Output	
19		GND	Ground	1
20		GND	Ground	1
21	CML-O	Rx2n	Receiver Inverted Data Output	
22	CML-O	Rx2p	Receiver Non-Inverted Data Output	
23		GND	Ground	1
24	CML-O	Rx4n	Receiver Inverted Data Output	
25	CML-O	Rx4p	Receiver Non-Inverted Data Output	
26		GND	Ground	1
27	LVTTL-O	ModPrsL	Module Present	
28	LVTTL-O	IntL/RX_LOS	Interrupt/Rx LOS	5
29		VccTx	+3.3 V Power Supply transmitter	2



**CL-Q28-LR-10-27**  
**Single-Mode QSFP28 100G BIDI 10km Transceiver**  
**RoHS 6 compliant**

30		Vcc1	+3.3 V Power Supply	2
31	LVTTL-I	LPMode/Tx_DIS	Low Power mode/Tx Disable	5
32		GND	Ground	1
33	CML-I	Tx3p	Transmitter Non-Inverted Data Input	
34	CML-I	Tx3n	Transmitter Inverted Data Input	
35		GND	Ground	1
36	CML-I	Tx1p	Transmitter Non-Inverted Data Input	
37	CML-I	Tx1n	Transmitter Inverted Data Input	
38		GND	Ground	1

Note1.GND is the symbol for signal and supply (power) common for QSFP28 modules. All are common within the QSFP28 module and all module voltages are referenced to this potential. unless otherwise noted. Connect these directly to the host board signal common ground plane.

Note2. Vcc Rx, Vcc1 and Vcc Tx are the receiver and transmitter power suppliers and shall be applied concurrently. Vcc Rx, Vcc1 and Vcc Tx may be internally connected within the QSFP28 transceiver module in any combination. The connector pins are each rated for a maximum current of 1000mA.

Note3.Timing for SCL, SDA and ModSel shall comply with the common management interface document SFF-8636 and SFF-8679.

Note4.The QSFP28 module must support hardware reset operation.

Note5.Two Multi-Purpose PIN for supporting Tx\_DIS and Rx\_LOS function in the 100G QSFP28 module.The IIC interface must function normally when the QSFP28 module is in the LP mode.

### Host Board Power Supply Filtering

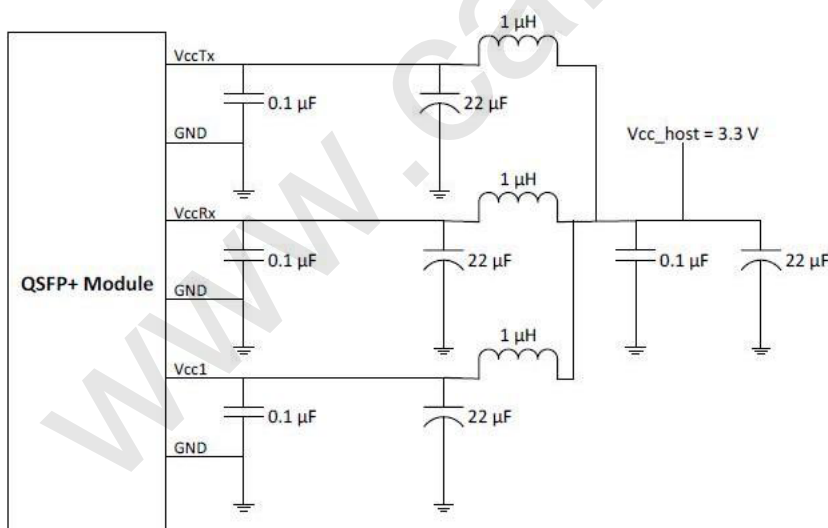

Figure2 Recommended host board power supply filtering



**CL-Q28-LR-10-27**  
**Single-Mode QSFP28 100G BIDI 10km Transceiver**  
**RoHS 6 compliant**

**Mechanical Specifications**

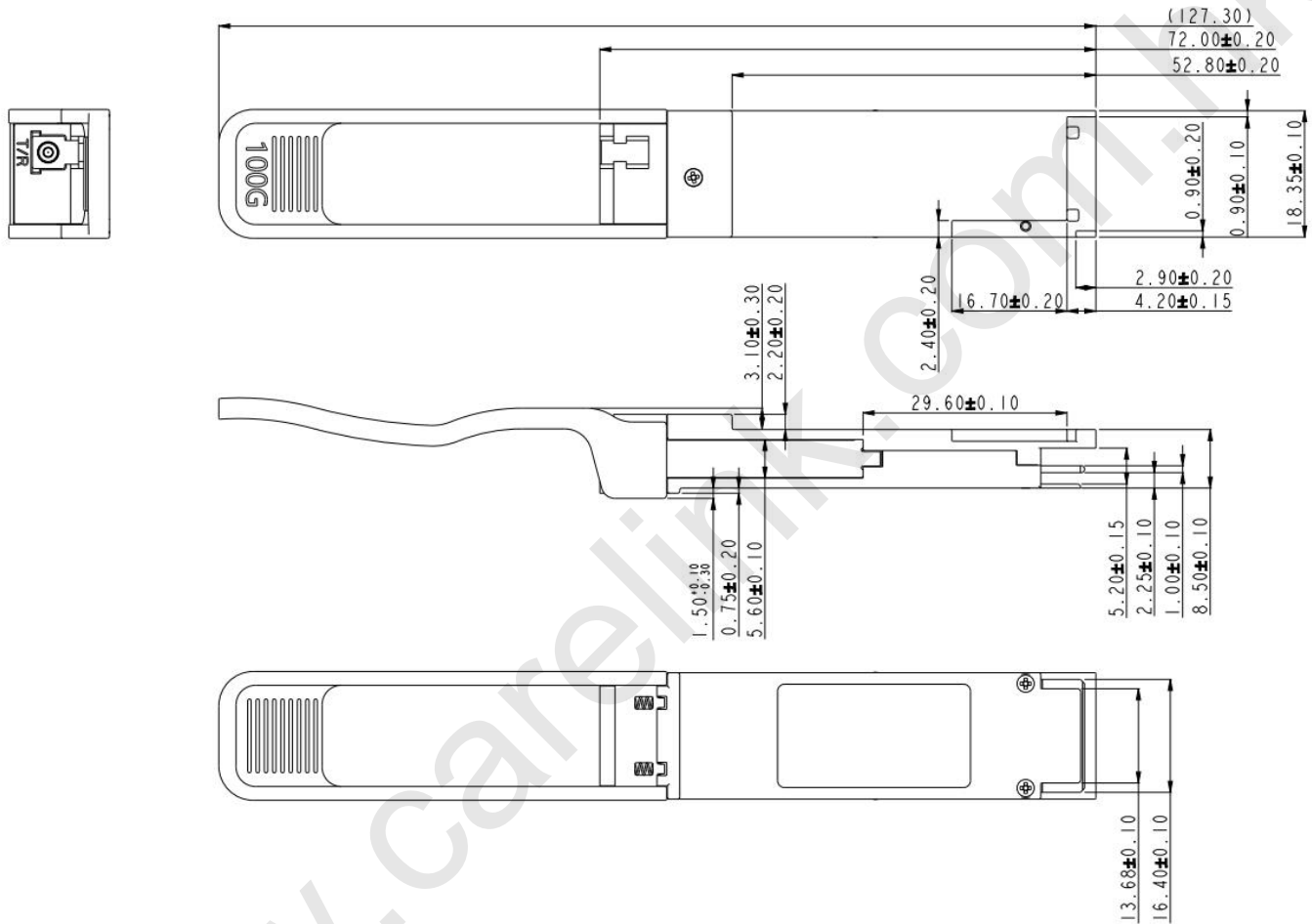

Figure3 100G LR1 BIDI QSFP28 Mechanical Dimensions

**Notice:**

Carelink reserves the right to make changes or discontinue any optical link product or service identified in this publication, without notice, in order to improve design and/or performance.

Applications that are described herein for any of the optical link products are for illustrative purposes only. Carelink makes no representation or warranty that such applications will be suitable for the specified use without further testing or modification.