

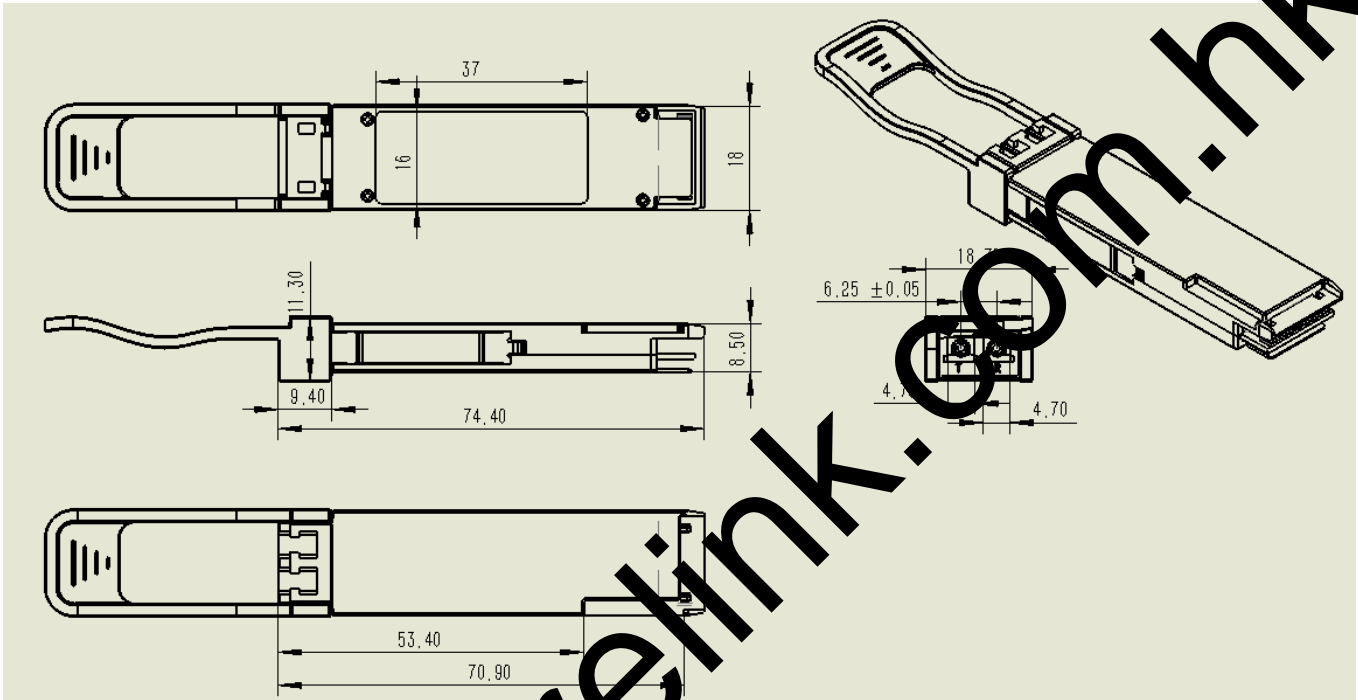

RoHS compliant
CL-QSFP+ LR4
40Gb/s 10km QSFP+ Transceiver
Hot Pluggable, Duplex LC Connector, Single mode

Mechanical Dimensions:



Notice:

Carelink reserves the right to make changes or discontinue any optical link product or service identified in this publication, without notice, in order to improve design and/or performance. Applications that are described herein for any of the optical link products are for illustrative purposes only. Carelink makes no representation or warranty that such applications will be suitable for the specified use without further testing or modification.