



**RoHS compliant**  
**Small Form Pluggable (XFP)**  
**XFP DWDM 80KM Optical Transceivers**

### Product Features

- Hot-pluggable XFP footprint
- Supports 9.95Gb/s to 11.3Gb/s bit rates
- Supports Lineside and XFI loopback
- RoHS-6 Compliant (lead-free)
- Power dissipation <3.5W
- Case temperature range:0°C to 70°C
- Maximum link length of 80km
- DWDM EML and APD Receiver
- Full Duplex LC connector
- No Reference Clock required
- Built-in digital diagnostic functions
- Standard bail release mechanism



### Ordering Information

PART NUMBER	TX/RX	INPUT/OUTPUT	SIGNAL DETECT	TEMPERATURE	PACKAGE	Distance
CL-XFP-D80-XX		AC/AC	TTL	-5°C to 70 °C	LC	80km

### Description

CL-XFP-D80-XX Small Form Factor 10Gb/s (XFP) transceivers are compliant with the current XFP Multi-Source Agreement (MSA) Specification. They comply with 10-Gigabit Ethernet 10GBASE-ZR/ZW per IEEE 802.3ae. Digital diagnostics functions are available via a 2-wire serial interface, as specified in the XFP MSA. The transceiver is RoHS compliant and leads free per Directive 2002/95/EC



RoHS compliant  
Small Form Pluggable (XFP)  
XFP DWDM 80KM Optical Transceivers

## I . Absolute Maximum Ratings

Parameter	Symbol	Min	Typ	Max	Unit	NOTE
Maximum Supply Voltage 1	Vcc3	-0.5		4.0	V	
Maximum Supply Voltage 2	Vcc5	-0.5		6.0	V	
Storage Temperature	T <sub>s</sub>	-40		85	°C	
Case Operating Temperature	T <sub>case</sub>	0		70	°C	

## II. Electrical Characteristics

Parameter	Symbol	Min	Typ	Max	Unit	NOTE
Main Supply Voltage	Vcc5	4.75		5.25	V	
Supply Voltage #2	Vcc3	3.13		3.45	V	
Supply Current – Vcc5 supply	Icc5			350	mA	
Supply Current – Vcc3 supply	Icc3			450	mA	
Module total power	P			3.5	W	1
<b>Transmitter</b>						
Input differential impedance	R <sub>in</sub>		100		Ω	2
Differential data input swing	V <sub>in,pp</sub>	120		820	mV	
Transmit Disable Voltage	V <sub>D</sub>	2.0		Vcc	V	3
Transmit Enable Voltage	V <sub>EN</sub>	GND		GND+ 0.8	V	
Transmit Disable Assert Time				10	us	
<b>Receiver</b>						
Differential data output swing	V <sub>out,pp</sub>	340	650	850	mV	4
Data output rise time	t <sub>r</sub>			38	ps	5
Data output fall time	t <sub>f</sub>			38	ps	5
LOS Fault	V <sub>LOS fault</sub>	Vcc – 0.5		V <sub>CCHOST</sub>	V	6
LOS Normal	V <sub>LOS norm</sub>	GND		GND+0.5	V	6
Power Supply Rejection	PSR		See Note 6 below			7

### Notes:

1. Maximum total power value is specified across the full temperature and voltage range.
2. After internal AC coupling.
3. Or open circuit.
4. Into 100 ohms differential termination.
5. These are unfiltered 20-80% values
6. Loss Of Signal is open collector to be pulled up with a 4.7k – 10kohm resistor to 3.15 – 3.6V. Logic 0 indicates normal operation; logic 1 indicates no signal detected.
7. Per Section 2.7.1. in the XFP MSA Specification



**RoHS compliant  
Small Form Pluggable (XFP)  
XFP DWDM 80KM Optical Transceivers**

### III. Optical Characteristics

Parameter	Symbol	Min	Typ	Max	Unit	NOTE
<b>Transmitter</b>						
Average Optical Power	$P_f$	0		5	dBm	
Optical Wavelength	$\lambda_c$	$\lambda_c - 0.1$		$\lambda_c + 0.1$	nm	
Center Wavelength Spacing			100		GHz	2
Side mode Suppression ratio	SMSR	30			dB	
Optical Extinction Ratio	ER	9			dB	
Transmitter and Dispersion Penalty	TDP			3	dB	
Average Launch power of OFF transmitter	$P_{OFF}$			-30	dBm	
Relative Intensity Noise	RIN			-130	dB/Hz	
<b>Receiver</b>						
Receiver Sensitivity	$P_{sen}$			-24	dBm	1
Input Saturation Power (Overload)	$P_{sat}$	-6			dBm	
Wavelength Range	$\lambda_c$	1260		1600	nm	
Receiver Reflectance	$R_{rx}$			-27	dB	
LOS De-Assert	$LOS_D$			-27	dBm	
LOS Assert	$LOS_A$	-37			dBm	
LOS Hysteresis		0.5			dB	

Notes:

1. Measured with worst ER; BER<10<sup>-12</sup>with 10.3Gbps, 2<sup>31</sup> – 1 PRBS.
2. Corresponds to approximately 0.8 nm.

### IV. Pin Assignment

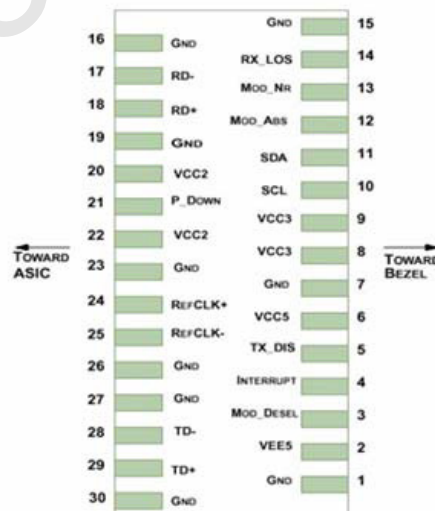

Diagram of Host Board Connector Block Pin Numbers and Name



**RoHS compliant**  
**Small Form Pluggable (XFP)**  
**XFP DWDM 80KM Optical Transceivers**

Pin	Logic	Symbol	Name/Description	NOTE
1		GND	Module Ground	1
2		VEE5	Optional -5.2 Power Supply – Not required	
3	LVTTL-I	Mod-Desel	Module De-select; When held low allows the module to respond to 2-wire serial interface commands	
4	LVTTL-O	Interrupt	Interrupt (bar); Indicates presence of an important condition which can be read over the serial 2-wire interface	2
5	LVTTL-I	TX_DIS	Transmitter Disable; Transmitter laser source turned off	
6		VCC5	+5 Power Supply	
7		GND	Module Ground	1
8		VCC3	+3.3V Power Supply	
9		VCC3	+3.3V Power Supply	
10	LVTTL-I	SCL	Serial 2-wire interface clock	2
11	LVTTL/O	SDA	Serial 2-wire interface data line	2
12	LVTTL-O	Mod_Abs	Module Absent; Indicates module is not present. Grounded in the module.	2
13	LVTTL-O	Mod_NR	Module Not Ready; CARELINK defines it as a logical OR between RX_LOS	2
14	LVTTL-O	RX_LOS	Receiver Loss of Signal indicator	2
15		GND	Module Ground	1
16		GND	Module Ground	1
17	CML-O	RD-	Receiver inverted data output	
18	CML-O	RD+	Receiver non-inverted data output	
19		GND	Module Ground	1
20		VCC2	+1.8V Power Supply – Not required	
21	LVTTL-I	P_Down/RST	Power Down; When high, places the module in the low power stand-by mode and on the falling edge of P_Down initiates a module reset Reset; The falling edge initiates a complete reset of the module including the 2-wire serial interface, equivalent to a power cycle.	
22		VCC2	+1.8V Power Supply – Not required	
23		GND	Module Ground	1
24	PECL-I	RefCLK+	Reference Clock non-inverted input, AC coupled on the host board – Not required	3
25	PECL-I	RefCLK-	Reference Clock inverted input, AC coupled on the host board – Not required	3
26		GND	Module Ground	1
27		GND	Module Ground	1
28	CML-I	TD-	Transmitter inverted data input	
29	CML-I	TD+	Transmitter non-inverted data input	
30		GND	Module Ground	1

**Notes:**

1. Module circuit ground is isolated from module chassis ground within the module.
2. 2 Open collector; should be pulled up with 4.7k – 10kohms on host board to a voltage between 3.15V and 3.6V.
3. A Reference Clock input is not required by the CL-XFP-D80-XX. If present, it will be ignored.



**RoHS compliant**  
**Small Form Pluggable (XFP)**  
**XFP DWDM 80KM Optical Transceivers**

## V. General Specifications

Parameter	Symbol	Min	Typ	Max	Units	NOTE
Bit Rate	BR	9.95		11.3	Gb/s	1
Bit Error Ratio	BER			$10^{-12}$		2
Max. Supported Link Length	L <sub>MAX</sub>			80	km	1

Notes:

1. 10GBASE-ZR/ZW
2. Tested with 2<sub>31</sub>-1 PRBS

## VI. Digital Diagnostic Functions

As defined by the XFP MSA, CARELINK XFP transceivers provide digital diagnostic functions via a 2-wire serial interface, which allows real-time access to the following operating parameters:

- Transceiver temperature
- Laser bias current
- Transmitted optical power
- Received optical power
- Transceiver supply voltage

It also provides a sophisticated system of alarm and warning flags, which may be used to alert end-users when particular operating parameters are outside of a factory-set normal range.

The operating and diagnostics information is monitored and reported by a Digital Diagnostics Transceiver Controller (DDTC) inside the transceiver, which is accessed through the 2-wire serial interface. When the serial protocol is activated, the serial clock signal (SCL pin) is generated by the host. The positive edge clocks data into the XFP transceiver into those segments of its memory map that are not write-protected. The negative edge clocks data from the XFP transceiver. The serial data signal (SDA pin) is bi-directional for serial data transfer. The host uses SDA in conjunction with SCL to mark the start and end of serial protocol activation. The memories are organized as a series of 8-bit data words that can be addressed individually or sequentially. The 2-wire serial interface provides sequential or random access to the 8 bit parameters, addressed from 000h to the maximum address of the memory.

For more detailed information including memory map definitions, please see the XFP MSA Specification.



RoHS compliant  
Small Form Pluggable (XFP)  
XFP DWDM 80KM Optical Transceivers

**VII. CL-XFP-D80-XX center wavelength**  
**C-band  $\lambda_c$  Wavelength Guide Pin Descriptions**

Channel	Wavelength (nm)	Frequency (THZ)	Channel	Wavelength (nm)	Frequency (THZ)
C17	1563.86	191.70	C39	1546.12	193.90
C18	1563.05	191.80	C40	1545.32	194.00
C19	1562.23	191.90	C41	1544.53	194.10
C20	1561.42	192.00	C42	1543.73	194.20
C21	1560.61	192.10	C43	1542.94	194.30
C22	1559.79	192.20	C44	1542.14	194.40
C23	1558.98	192.30	C45	1541.35	194.50
C24	1558.17	192.40	C46	1540.56	194.60
C25	1557.36	192.50	C47	1539.77	194.70
C26	1556.55	192.60	C48	1538.98	194.80
C27	1555.75	192.70	C49	1538.19	194.90
C28	1554.94	192.80	C50	1537.40	195.00
C29	1554.13	192.90	C51	1536.61	195.10
C30	1553.33	193.00	C52	1535.82	195.20
C31	1552.52	193.10	C53	1535.04	195.30
C32	1551.72	193.20	C54	1534.25	195.40
C33	1550.92	193.30	C55	1533.47	195.50
C34	1550.12	193.40	C56	1532.68	195.60
C35	1549.32	193.50	C57	1531.90	195.70
C36	1548.51	193.60	C58	1531.12	195.80
C37	1547.72	193.70	C59	1530.33	195.90
C38	1546.92	193.80	C60	1529.55	196.00
Non-ITU	Peak wavelength between 1528.77nm-1563.86		C61	1528.77	196.10



**RoHS compliant**  
**Small Form Pluggable (XFP)**  
**XFP DWDM 80KM Optical Transceivers**

**VIII. Mechanical Specifications**

CARELINK's XFP transceivers are compliant with the dimensions defined by the XFP Multi-Sourcing Agreement (MSA).

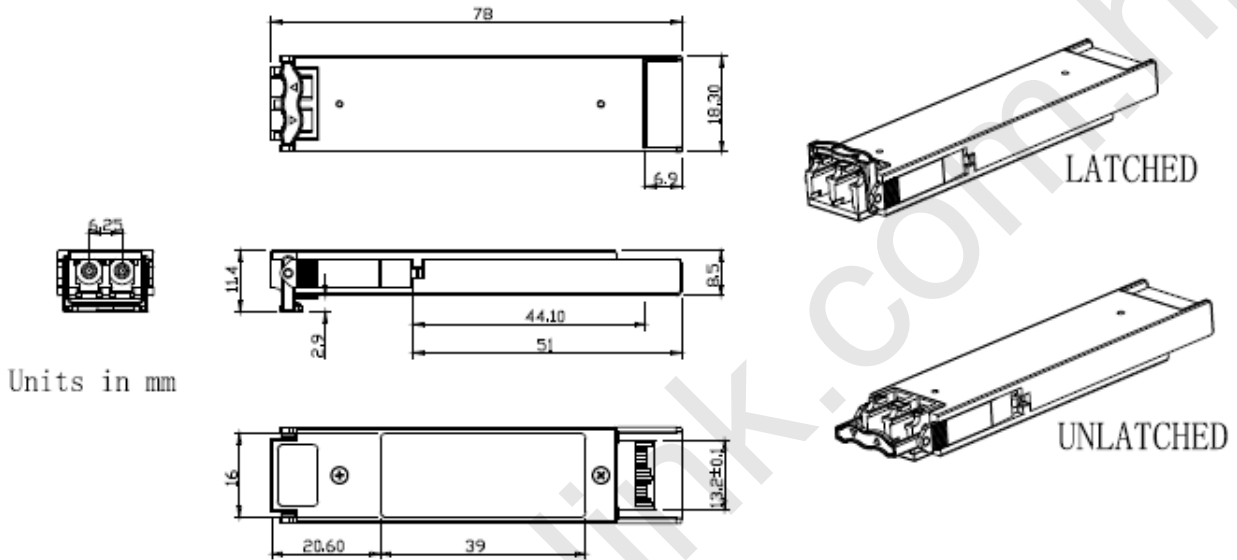

Units in mm

XFP Transceiver (dimensions are in mm)

**IX. PCB Layout and Bezel Recommendations**

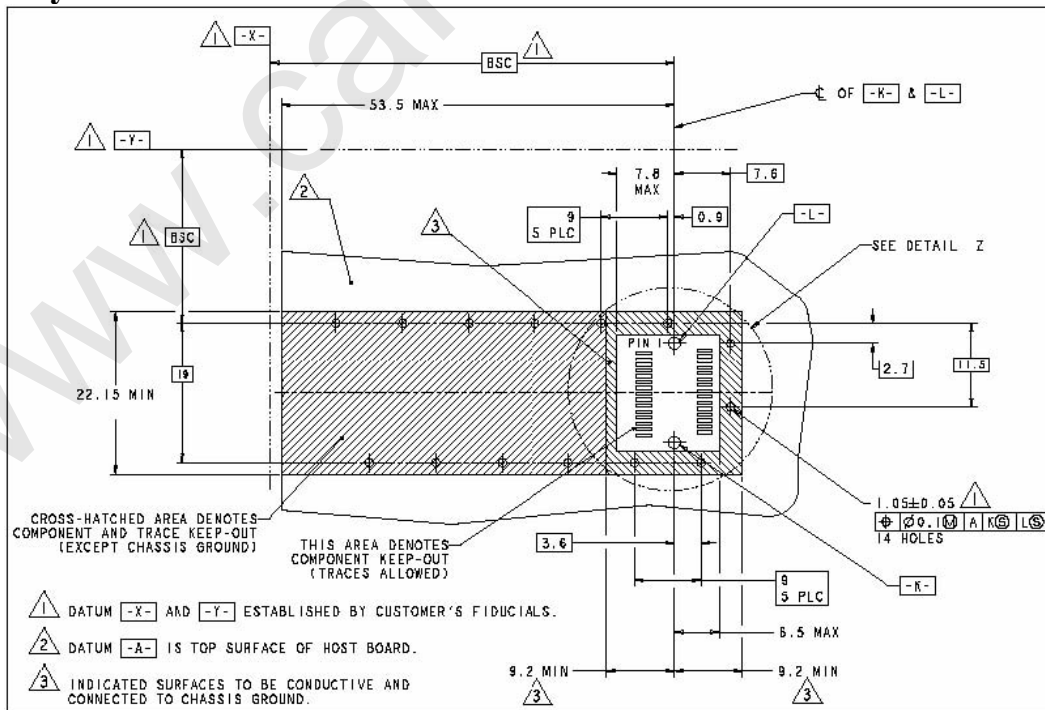

XFP Host Board Mechanical Layout (dimensions are in mm)





**RoHS compliant**  
**Small Form Pluggable (XFP)**  
**XFP DWDM 80KM Optical Transceivers**

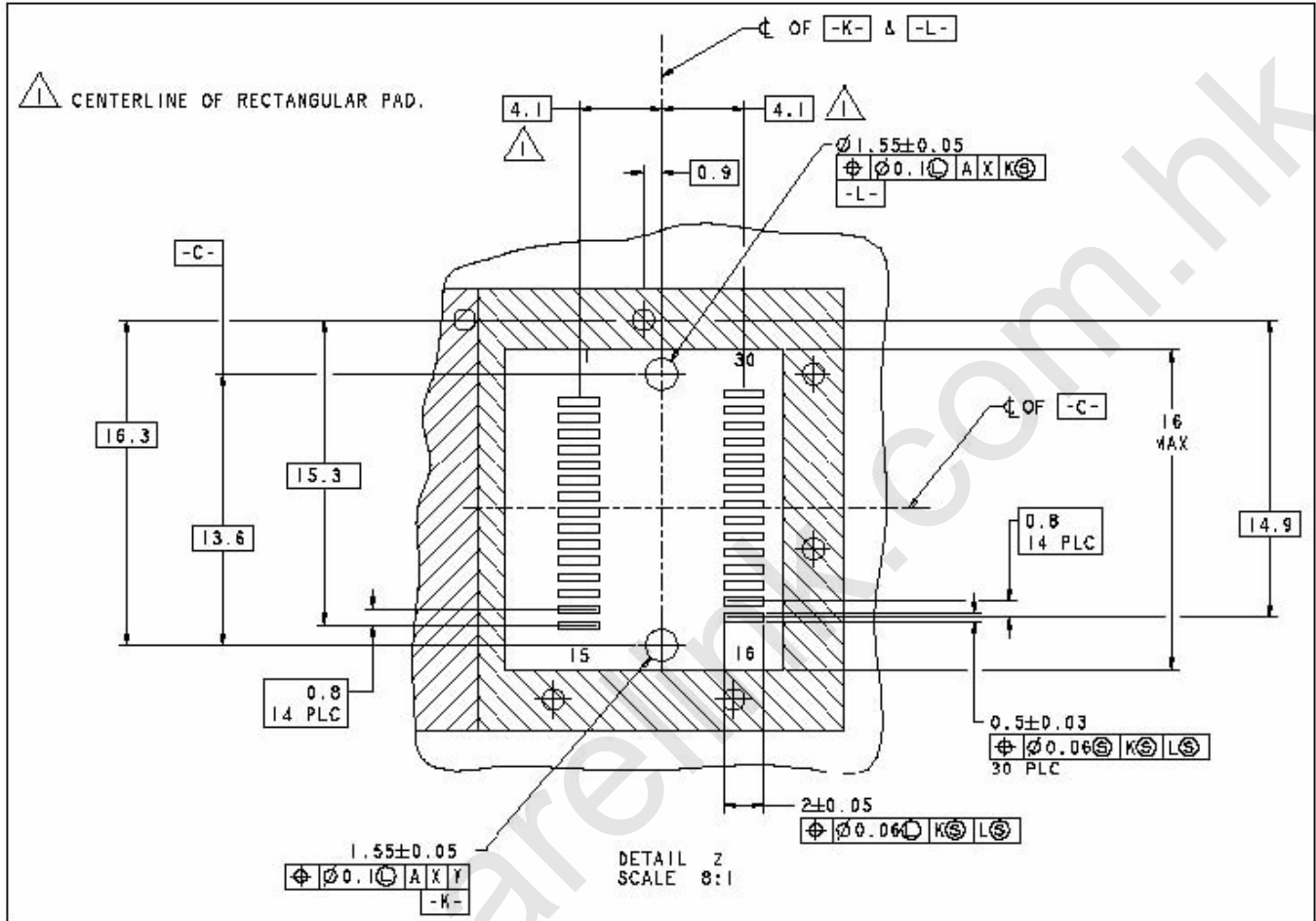

**XFP Detail Host Board Mechanical Layout (dimensions are in mm)**

## X. Regulatory Compliance

Feature	Reference	Performance
Electrostatic discharge (ESD)	IEC/EN 61000-4-2	Compatible with standards
Electromagnetic Interference (EMI)	FCC Part 15 Class B EN 55022 Class B (CISPR 22A)	Compatible with standards
Laser Eye Safety	FDA 21CFR 1040.10, 1040.11 IEC/EN 60825-1, 2	Class 1 laser product
Component Recognition	IEC/EN 60950 , UL	Compatible with standards
ROHS	2002/95/EC	Compatible with standards
EMC	EN61000-3	Compatible with standards

Carelink reserves the right to make changes or discontinue any optical link product or service identified in this publications, without notice, in order to improve design and/or performance. Applications that are described herein for any of the optical link products are for illustrative purposes only. Carelink make no representations or warranty that such applications will be suitable for the specified use without further testing or modifications.