



RoHS compliant
10GBASE-LR/LW
CWDM XFP Single-Mode Optical Transceiver for 10GbE / 10GFC



Features

- Support 9.95 Gbps to 10.5 Gbps
- Complaint with XFP MSA
- Compliant to IEEE 802.3ae 10GBASE-LR/LW
- Compliant to 10GFC 1200-SM-LL-L
- Compliant with XFI 10G Serial Electrical Interface
- Maximum Link Length of 10 km
- Uncooled 18-Wavelength CWDM DFB LD
- 2-Wire Interface for Integrated Digital Diagnostic Monitoring
- XFI Loopback Mode
- No reference Clock required
- Only Required +3.3 V Power Supply
- Power Consumption < 2 W
- RoHS Compliant
- -5 to 70°C Case Operating Temperature
- Duplex LC Connector

Laser Safety

This single-mode transceiver is a Class 1 laser product. It complies with IEC-60825 and FDA 21 CFR 1040.10 and 1040.11. The transceiver must be operated within the specified temperature and voltage limits. The optical ports of the module shall be terminated with an optical connector or with a dust plug.

Application

- 10GBASE-LR at 10.3125 Gb/s
- 10GBASE-LW at 9.953 Gb/s
- 10GFC at 10.51875 Gb/s

Description

CL-XFP-C10-XX series transceiver is designed for single-mode fibre serial optical data communications such as 10G Ethernet 10GBASE-LR/LW and 10G Fibre Channel 1200-SM-LL-L. This module is designed for single mode fiber and operates at a nominal wavelength of CWDM wavelength. There are eighteen center wavelengths available from 1270nm to 1610 nm, with each step 20 nm. A guaranteed minimum optical link budget of 11 dB is offered. The transceiver consists of two sections: The transmitter section consists of a directly modulated uncooled CWDM DFB laser, driver and signal conditioner. The receiver section incorporates a PIN photodiode integrated with a trans-impedance preamplifier (TIA) and signal conditioner. The module is with the XFP 30-pin connector to allow hot plug capability. Integrated Tx and Rx signal conditioners provide high jitter-tolerance for full XFI compliance and no external reference clock required. The internally ac coupled high speed serial I/O simplifies interfacing to external circuitry. Only single 3.3V power supply is needed. The optical output can be disabled by LVTTTL logic high-level input of TX_DIS. Loss of signal (RX_LOS) output is provided to indicate the loss of an input optical signal of receiver. A serial EEPROM in the transceiver allows the user to access transceiver digital diagnostic monitoring and configuration data via the 2-wire XFP Management Interface. This interface uses a single address, A0h, with a memory map divided into a lower and upper area. Basic digital diagnostic data is held in the lower area while specific data is held in a series of tables in the high memory area.

Ordering Information

PART NUMBER	Bit Rate (Gb/s)	10GBASE	Power Budget (dB)	Wavelength (nm)	Package	Temp (oC)	RoHS Compliant
CL-XFP-C10-XX	9.95 – 10.52	LR/LW	> 11	CWDM*	XFP with DMI	-5 to 70	Yes
CL-XFP-C10-XXe	9.95 – 10.52	LR/LW	> 11	CWDM*	XFP with DMI	-30 to 70	Yes
CL-XFP-C10-XXi	9.95 – 10.52	LR/LW	> 11	CWDM*	XFP with DMI	-40 to 85	Yes



RoHS compliant
10GBASE-LR/LW
CWDM XFP Single-Mode Optical Transceiver for 10GbE / 10GFC

Central Wavelength	Min. (nm)	Typ. (nm)	Max. (nm)	Label	Central Wavelength	Min. (nm)	Typ. (nm)	Max. (nm)	Label
-C270	1264.5	1270	1277.5	C27	-C450	1444.5	1450	1457.5	C45
-C290	1284.5	1290	1297.5	C29	-C470	1464.5	1470	1477.5	C47
-C310	1304.5	1310	1317.5	C31	-C490	1484.5	1490	1497.5	C49
-C330	1324.5	1330	1337.5	C33	-C510	1504.5	1510	1517.5	C51
-C350	1344.5	1350	1357.5	C35	-C530	1524.5	1530	1537.5	C53
-C370	1364.5	1370	1377.5	C37	-C550	1544.5	1550	1557.5	C55
-C390	1384.5	1390	1397.5	C39	-C570	1564.5	1570	1577.5	C57
-C410	1404.5	1410	1417.5	C41	-C590	1584.5	1590	1597.5	C59
-C430	1424.5	1430	1437.5	C43	-C610	1604.5	1610	1617.5	C61

CWDM*: 18 Wavelengths from 1270 nm to 1610 nm, each step 20 nm.

Absolute Maximum Ratings					
Parameter	Symbol	Min	Max	Units	Notes
Storage Temperature	T _{stg}	-40	85	°C	
Operating Case Temperature	T _{opr}	-5	70	°C	
Relative Humidity	RH	0	85	%	Non condensing
Power Supply Voltage	V _{CC3}	0	3.6	V	

Recommended Operating Conditions					
Parameter	Symbol	Min	Typ	Max	Units / Notes
Power Supply Voltage	V _{CC3}	3.13	3.3	3.47	V
Power Supply Current (@3.3V)	I _{CC3}			550	mA
Power Dissipation	P _D			2	W
Operating Case Temperature	T _{opr}	-5		70	°C
Data Rate		9.95		10.52	Gb/s

Transmitter Optical Specifications (T _{opr} = -5 to 70°C, V _{CC3} = 3.3V ±5%)						
Parameter	Symbol	Min	Typ	Max	Units	Notes
Average Launch Power	P _{O, Avg}	-3		1	dBm	1
Optical Modulation Amplitude	P _{O, OMA}	-5.0			dBm	
Extinction Ratio	ER	3.5			dB	
Output Center Wavelength	λ _c	λ _c -5.5	λ _c	λ _c +7.5	nm	2
Output Spectrum Width	σ _λ			1	nm	-20 dB width
Side Mode Suppression Ratio	SMSR	30			dB	
Relative Intensity Noise	RIN			-128	dB/Hz	
Optical Eye Mask	Compliant with IEEE 802.3ae 10GBASE-L XFP MSA					
Average Launch Power of OFF Transmitter				-30	dBm	

- Output power is power coupled into a 9/125 μm single-mode fiber.
- ITU-T G.694.2 CWDM wavelength from 1470 nm to 1610 nm, each step 20 nm.



RoHS compliant
10GBASE-LR/LW
CWDM XFP Single-Mode Optical Transceiver for 10GbE / 10GFC

Receiver Optical Specifications (Topr = -5 to 70°C, Vcc3 = 3.3V ±5%)						
Parameter	Symbol	Min	Typ	Max	Units	Notes
Sensitivity	Sen1			-14.4	dBm	3
Receiver Overload	P _{MAX}	0.5	---		dBm	
LOS -- Deasserted	LOS _D	---	---	-15	dBm	Transition: low to high
LOS -- Asserted	LOS _A	-26	---	---	dBm	Transition: high to low
LOS -- Hysteresis		1	---	5	dB	
Wavelength of Operation	λ _c	1260		1620	nm	
Optical Return Loss	ORL			-12	dB	

3. Average received power; BER < 10⁻¹² and PRBS 2₃₁-1.

Electrical Characteristics						
Parameter	Symbol	Min	Typ	Max	Units	Notes
High-Speed Signal (CML) Interface Specification						
Input Data Rate		9.95	10.3125	10.52	Gb/s	
Differential Input Impedance	R _{in}		100		Ω	
Differential Data Input Amplitude		120		820	mVpp	1, Internally AC coupled
Output Data Rate		9.95	10.3125	10.52	Gb/s	
Differential Output Impedance	R _{out}		100		Ω	
Differential Data Output Amplitude		340		850	mVpp	1, Internally AC coupled
Low-Speed Signal (LVTTTL) Interface Specification						
Input High Voltage		2.0		V _{cc}	V	
Input Low Voltage		GND		0.8	V	
Output High Voltage		2.4		V _{cc}	V	
Output Low Voltage		GND		0.5	V	
Reference Clock (LVPECL) Interface Specification						
No reference clock						

The differential input and output amplitudes are per XFP MSA mask at points B' and C'.

Transceiver Timing Characteristics						
Parameter	Symbol	Min	Typ	Max	Units	Notes
TX_DIS Assert Time	t _{off}			10	μs	
TX_DIS Negate Time	t _{on}			2	ms	
Time to Initialize	t _{init}			300	ms	
Interrupt Assert Delay	interrupt on			200	ms	
Interrupt Negate Delay	interrupt off			500	μs	
P_Down/PST Assert Delay	P_Down/RST_on			100	μs	
P_Down Negate Delay	P_Down/RST_off			300	ms	
Mod_NR Assert Delay	Mod_nr_on			1	ms	
Mod_NR Negate Delay	Mod_nr_off			1	ms	
Mod_Desel Assert Time	T_Mod_Desel			2	ms	
Mod_Desel De-Assert Time	T_Mod_Sel			2	ms	
P_Down Reset Time	T_reset	10			μs	
RX_LOS Assert Delay	T_Los_on			100	μs	
RX_LOS Negate Delay	T_Los_off			100	μs	
Serial ID Clock Rate	f _{SCL}	0		400	kHz	



Management Interface

The structure of the memory map is shown in Figure 1, which is accessible over a 2-wire serial interface at the 8-bit address 1010000X (A0h). The normal 256 byte I2C address space is divided into low and upper blocks of 128 Bytes. The lower block of 128 Bytes is always directly available and is used for the diagnostics and control function. Multiple blocks of memories are available in the upper 128 Bytes of the address space. These are individually addressed through a table select Byte which the user enters into a location in the lower address space. Thus, there is a total available address space of 128*256 = 32 Kbytes in this upper memory space. The contents of Table 01h are listed in Table 1 below. Please refer SFF INF-8077i (Revision 4.5) for detailed information.

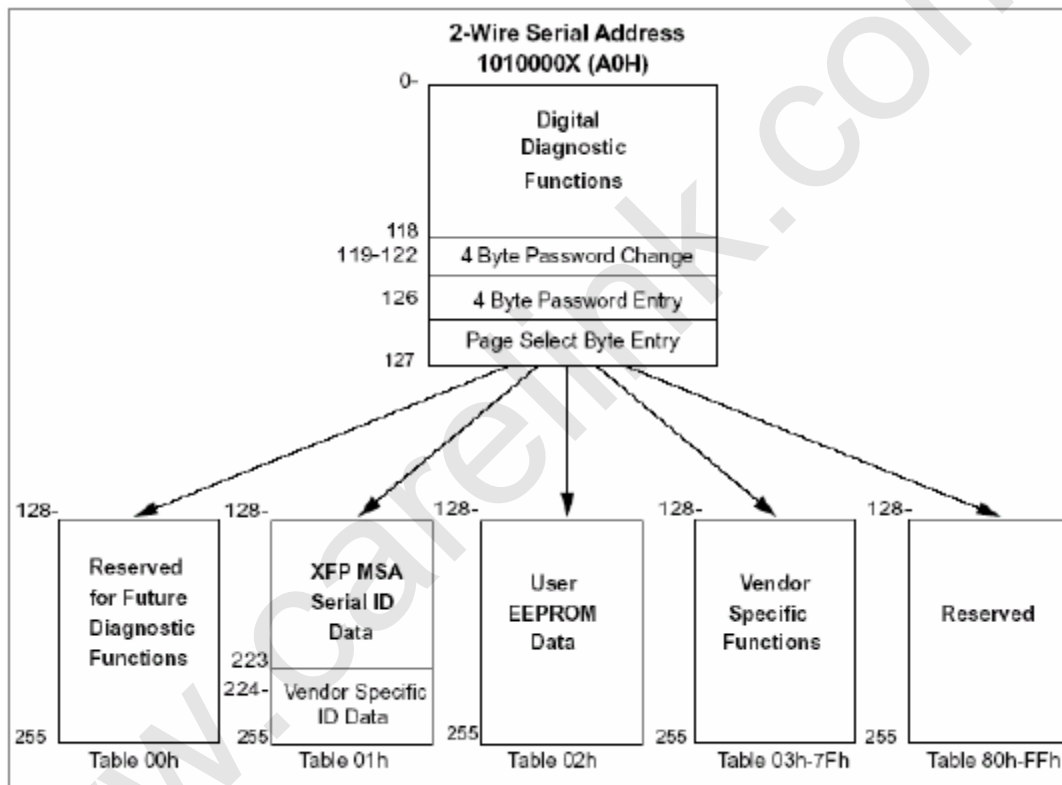

Figure 1. 2-wire Serial Digital Diagnostic Memory Map

Table 1 Monitoring Specification

Data Address	Parameter	Accuracy
96 ~ 97	Temperature	± 3°C
98 ~ 99	Reserved	
100 ~ 101	Tx Bias	± 10%
102 ~ 103	Tx Power	± 2dB
104 ~ 105	Rx Power	± 2dB
106 ~ 107	Vcc3	± 3%



RoHS compliant
 10GBASE-LR/LW
CWDM XFP Single-Mode Optical Transceiver for 10GbE / 10GFC

Connection Diagram

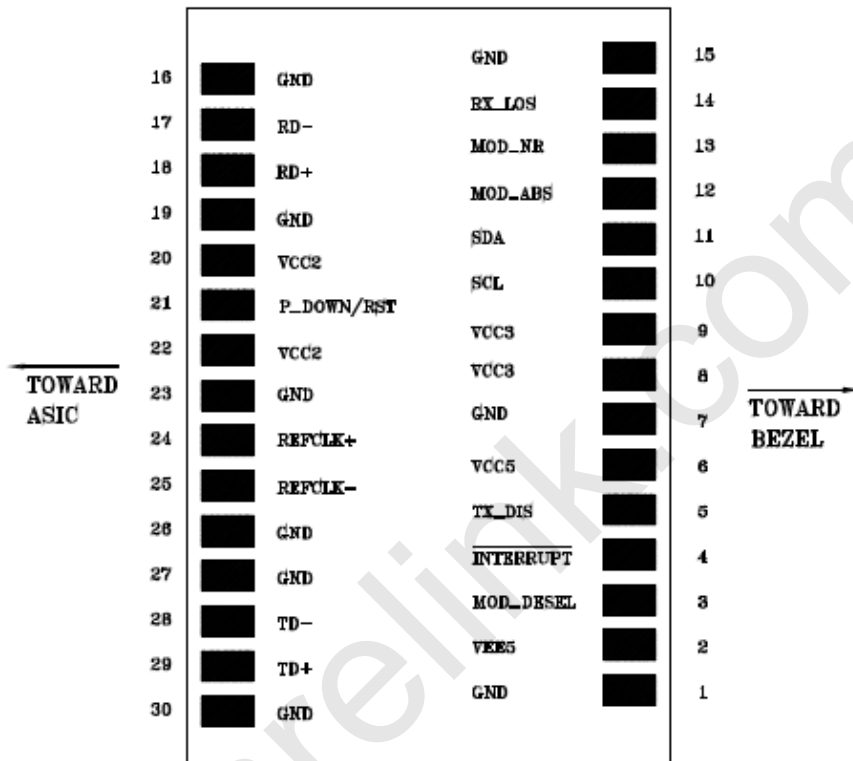



RoHS compliant
10GBASE-LR/LW
CWDM XFP Single-Mode Optical Transceiver for 10GbE / 10GFC

Table 3 PIN Description

PIN	Logic	Signal Name	Description	Note
1		GND	Module Ground	1
2		VEE5	-5.2V Power Supply (Not required)	3
3	LVTTL-I	Mod Desel	Module De-select, When held low allows module to respond to 2-wire serial interface	
4	LVTTL-O	Interrupt	Interrupt; Indicates presence of an important condition which can be read over the 2-wire serial interface	2
5	LVTTL-I	TX DIS	Transmitter Disable; Turns off transmitter laser output	
6		VCC5	+5V Power Supply (Not required)	3
7		GND	Module Ground	1
8		VCC3	+3.3V Power Supply	
9		VCC3	+3.3V Power Supply	
10	LVTTL-IO	SCL	Serial 2-wire interface clock	2
11	LVTTL-IO	SDA	Serial 2-wire interface data line	2
12	LVTTL-O	Mod Abs	Indicates Module is not present. Grounded in the Module	2
13	LVTTL-O	Mod NR	Module Not Ready; Indicating Module Operational Fault	2
14	LVTTL-O	RX LOS	Receiver Loss Of Signal Indicator	2
15		GND	Module Ground	1
16		GND	Module Ground	1
17	CML-O	RD-	Receiver Inverted Data Output	
18	CML-O	RD+	Receiver Non-Inverted Data Output	
19		GND	Module Ground	1
20		VCC2	+1.8V Power Supply (Not required)	3
21	LVTTL-I	P_Down/RST	Power down; When high, requires the module to limit power consumption to 1.5W or below. 2-Wire serial interface must be functional in the low power mode. Reset; The falling edge initiates a complete reset of the module including the 2-wire serial interface, equivalent to a power cycle.	
22		VCC2	+1.8V Power Supply (Not required)	3
23		GND	Module Ground	1
24	PECL-I	RefCLK+	Reference Clock Non-Inverted Input, AC coupled on the host board. (Not used. Internally terminated to 50 ohm (100 ohm diff.))	4
25	PECL-I	RefCLK-	Reference Clock Inverted Input, AC coupled on the host board. (Not used. Internally terminated to 50 ohm (100 ohm diff.))	4
26		GND	Module Ground	1
27		GND	Module Ground	1
28	CML-I	TD-	Transmitter Inverted Data Input	
29	CML-I	TD+	Transmitter Non-Inverted Data Input	
30		GND	Module Ground	1

1. Module ground pins GND are isolated from the module case and chassis ground within the module.
2. Shall be pulled up with 4.7K-10Kohms to a voltage between 3.15V and 3.45V on the host board.
3. These PINs are open within module.
4. A Reference Clock input is not required. If present, it will be ignored

Mechanical Specification (Units in mm)



RoHS compliant
 10GBASE-LR/LW
 CWDM XFP Single-Mode Optical Transceiver for 10GbE / 10GFC

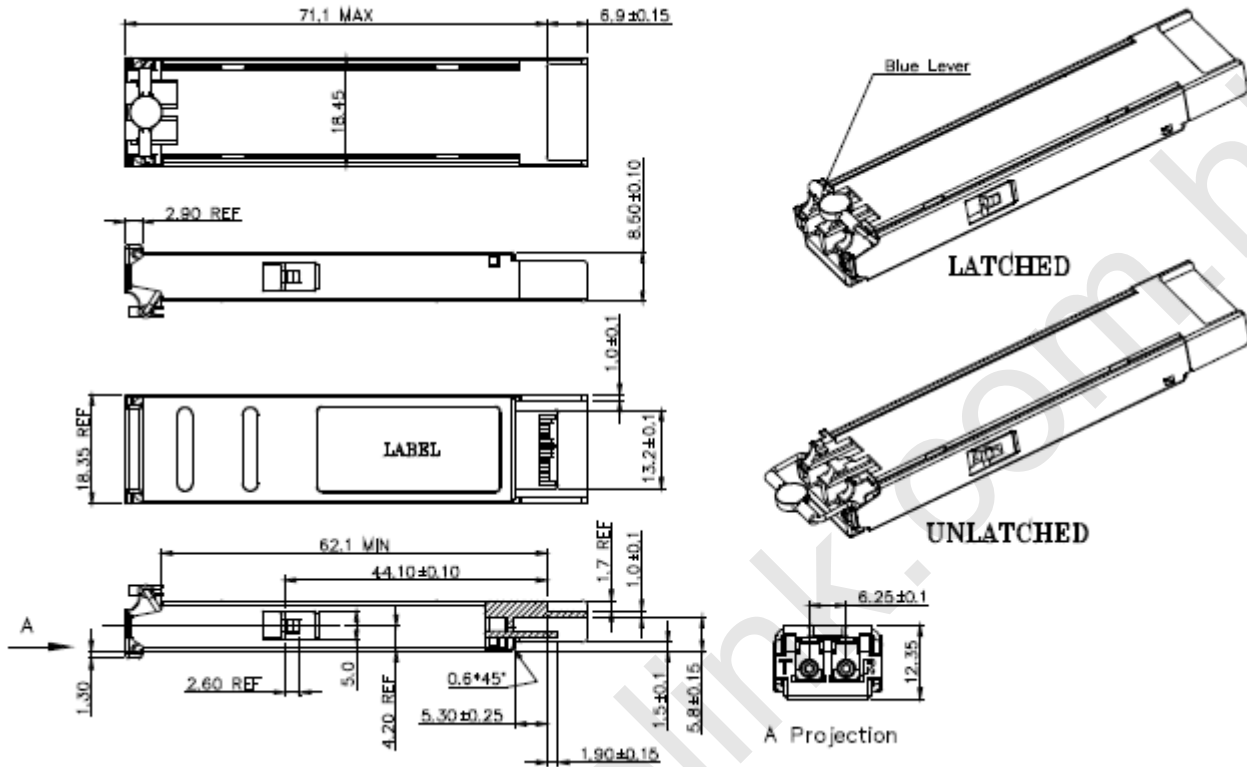

Recommended Power Circuit Schematic

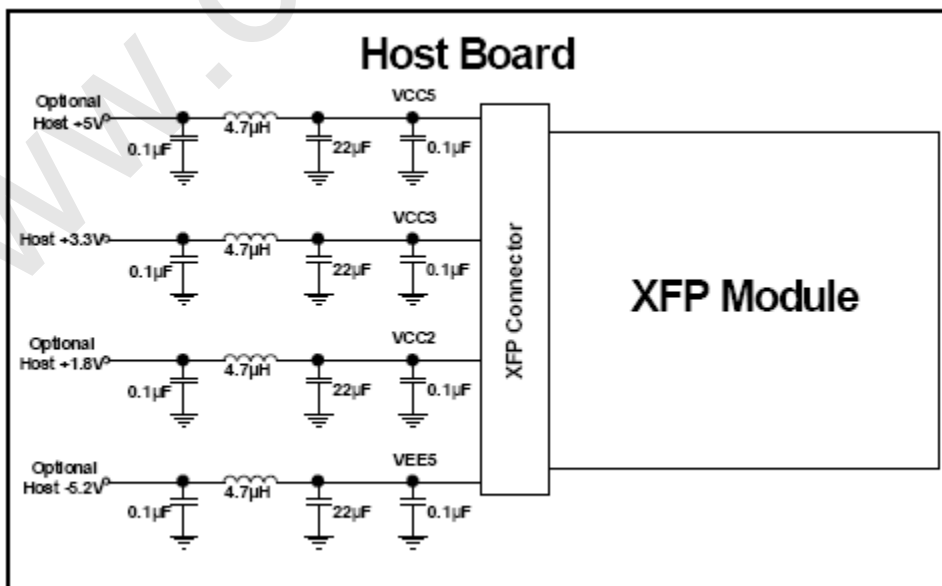



Recommended Interface Circuit

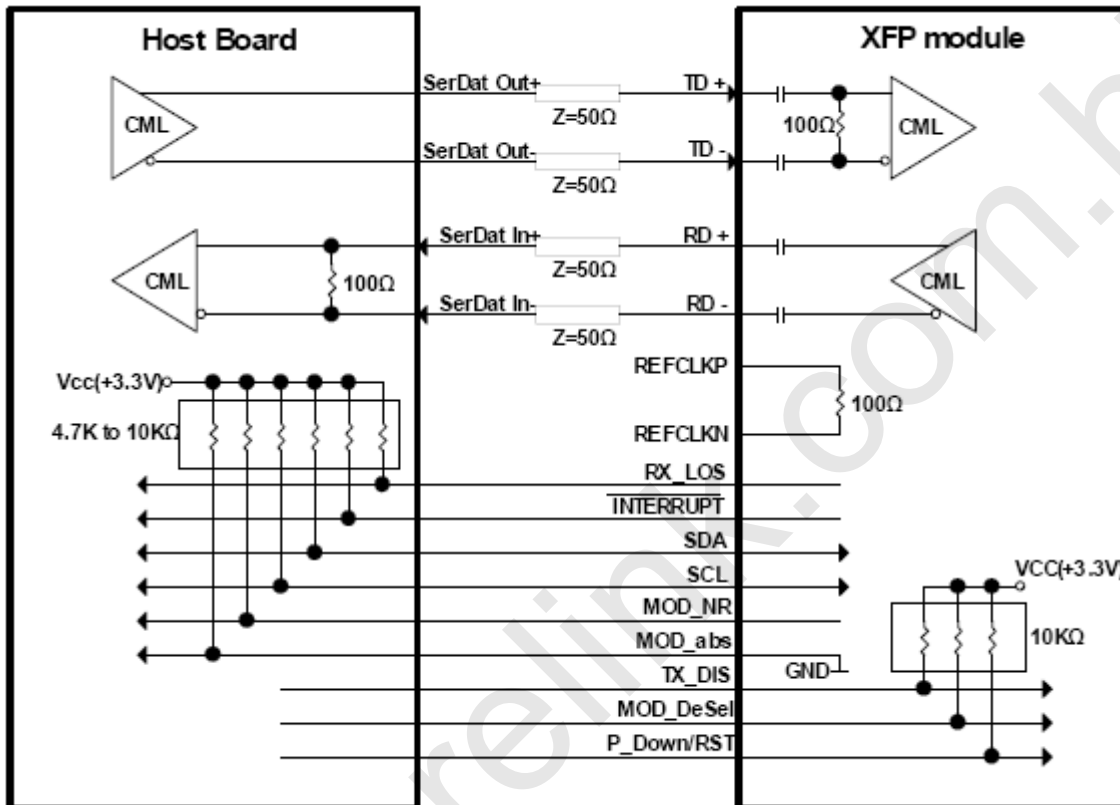

Table 2 Serial ID Memory Contents (Table 01h)



RoHS compliant
10GBASE-LR/LW
CWDM XFP Single-Mode Optical Transceiver for 10GbE / 10GFC

Address	Field Size (Byte)	Name of Filed	Description	Hex
128	1	Identifier	XFP	06
129	1	Ext. Identifier	power consumption <2.5W, no Ref Colck required	50
130	1	Connector type	LC connector	07
131~138	8	Transceiver	10GBASE-LR/LW, 10GFC 1200-SM-LL-L	44 40 00 00 00 00 00 00
139	1	Encoding	64B/66B & 8B10B	C0
140	1	BR-Min	9.9Gbps	63
141	1	BR-Max	10.5Gbps	69
142	1	length (SMF)-Km	10 Km	0A
143	1	Length (E-50µm)	0 m	00
144	1	Length (50 µm)	0 m	00
145	1	Length (62.5 µm)	0 m	00
146	1	Length (Copper)	0 m	00
147	1	Device Tech	Uncooled CWDM DFB, PIN detector	50
148~163	16	Vendor name	OPTOWAY	4F 50 54 4F 57 41 59 20 20 20 20 20 20 20 20 20
164	1	CDR Support	CDR supports 9.953G ~ 10.52G, XFI Loopback	E1
165~167	3	Vendor OUI		00 0E FA
168~183	16	Vendor PN	XX = 27, 29, 31, 33, 35, 37, 39, 41, 43, 45, 47, 49, 51, 53, 55, 57, 59, 61	58 50 53 2D 32 33 31 30 57 2D 43 xx xx 30 47 20
184~185	2	Vendor rev	ASCII ("31 61" means 1a revision)	xx xx
186~187	2	Wavelength	1XX1nm, XX=27,29,31,33,35,37,39,41,43,45,47,49,51,53,55,57,59,61	xx xx
188~189	2	Wavelength Tolerance	+/- 6.5nm	05 14
190	1	Max Case Temp	70deg	46
191	1	CC_BASE	Check sum of Byte 128 -- 190	
192~195	4	Power Supply	2Wmax, 1.5W pd max , 550mA 3.3V	64 96 06 00
196~211	16	Vendor SN	ASCII	xx xx xx xx xx xx xx xx xx xx xx xx xx xx xx xx
212~219	8	Date code	ASCII Year (2 Byte), Month (2 Byte), Day (2 Byte)	xx xx xx xx xx xx 20 20
220	1	Diagnostic Monitoring Type	No BER Support, Average Power	08
221	1	Enhanced Options	Optional Soft TX_DISABLE implemented, Optional Soft P_down implemented	60
222	1	Aux Monitoring	AUX1 for Vcc3.	70
223	1	CC_EXT	Check sum of Byte 192 -- 222	
224~255	32	Vendor Specific		Reserved

Note: Specifications subject to change without notice.