



**RoHS compliant**  
**TX-1270nm/RX-1330nm Single Fiber Bi-direction XFP Transceiver**  
**10GBASE-BX(Ethernet)**



### Features

- 10Gb/s serial optical interface compliant to 802.3ae 10GBASE-ZR, single LC connector for bi-directional application, up to 70km SMF
- Electrical interface compliant to SFF-8431 specifications for enhanced 8.5 and 10 Gigabit small form factor pluggable module "XFP"
- 1270/1330nm high power DFB transmitter, APD receiver, integrated WDM
- 2-wire interface for management specifications compliant with SFF 8472 digital diagnostic monitoring interface for optical transceivers
- Part number(0°C to 70°C):
  - CL-XFP-70-27, 1270TX/1330RX
  - Line side, client side loopback function
- Advanced firmware allow customer system encryption information to be stored in transceiver
- ROHS compliant

### Applications

- High-speed storage area networks
- Computer cluster cross-connect
- Custom high-speed data pipes
- Line side loop back
- Client side loop back

### Ordering Information

PART NUMBER	INPUT/OUTPUT	SIGNAL DETECT	VOLTAGE	TEMPERATURE
CL-XFP-70-27	AC/AC	TTL	3.3V	-10°C to 70 °C
CL-XFP-70-27i	AC/AC	TTL	3.3V	-25°C to 85 °C



**RoHS compliant**  
**TX-1270nm/RX-1330nm Single Fiber Bi-direction XFP Transceiver**  
**10GBASE-BX(Ethernet)**

## 1. GENERAL DESCRIPTION

This 10Gigabit XFPBiDi transceiver is designed to transmit and receive optical data over single mode optical fiber for link length 70km.

The XFP BiDi module electrical interface is compliant to XFI electrical specifications. The transmitter input and receiver output impedance is 100 Ohms differential. Data lines are internally AC coupled. The module provides differential termination and reduce differential to common mode conversion for quality signal termination and low EMI. SFI typically operates over 200 mm of improved FR4 material or up to about 150mm of standard FR4 with one connector.

The transmitter converts 10Gbit/s serial PECL or CML electrical data into serial optical data compliant with the 10GBASE-ZR standard. An open collector compatible Transmit Disable (Tx\_Dis) is provided. A logic "1," or no connection on this pin will disable the laser from transmitting. A logic "0" on this pin provides normal operation. The transmitter has an internal automatic power control loop (APC) to ensure constant optical power output across supply voltage and temperature variations. An open collector compatible Transmit Fault (Tx\_Fault) is provided. TX\_Fault is a module output contact that when high, indicates that the module transmitter has detected a fault condition related to laser operation or safety. The TX\_Fault output contact is an open drain/collector and shall be pulled up to the Vcc\_Host in the host with a resistor in the range 4.7-10 kΩ. TX\_Disable is a module input contact. When TX\_Disable is asserted high or left open, the XFP module transmitter output shall be turned off. This contact shall be pulled up to VccT with a 4.7 kΩ to 10 kΩ resistor.

The receiver converts 10Gbit/s serial optical data into serial PECL/CML electrical data. An open collector compatible Loss of Signal is provided. Rx\_LOS when high indicates an optical signal level below that specified in the relevant standard. The Rx\_LOS contact is an open drain/collector output and shall be pulled up to Vcc\_Host in the host with a resistor in the range 4.7-10 kΩ, or with an active termination. Power supply filtering is recommended for both the transmitter and receiver. The Rx\_LOS signal is intended as a preliminary indication to the system in which the XFP is installed that the received signal strength is below the specified range. Such an indication typically points to non-installed cables, broken cables, or a disabled, failing or a powered off transmitter at the far end of the cable.

## 2. PIN DEFINITION

The XFP BiDi modules are hot-pluggable. Hot pluggable refers to plugging in or unplugging a module while the host board is powered. XFP BiDi host connector is a 0.8 mm pitch 20 position right angle improved connector specified by SFF-8083, or stacked connector with equivalent with equivalent electrical performance. Host PCB contact assignment is shown in Figure 2 and contact definitions are given in Table 2. XFP BiDi module contacts mates with the host in the order of ground, power, followed by signal as illustrated by Figure 3 and the contact sequence order listed in Table 2.



**RoHS compliant**  
**TX-1270nm/RX-1330nm Single Fiber Bi-direction XFP Transceiver**  
**10GBASE-BX(Ethernet)**

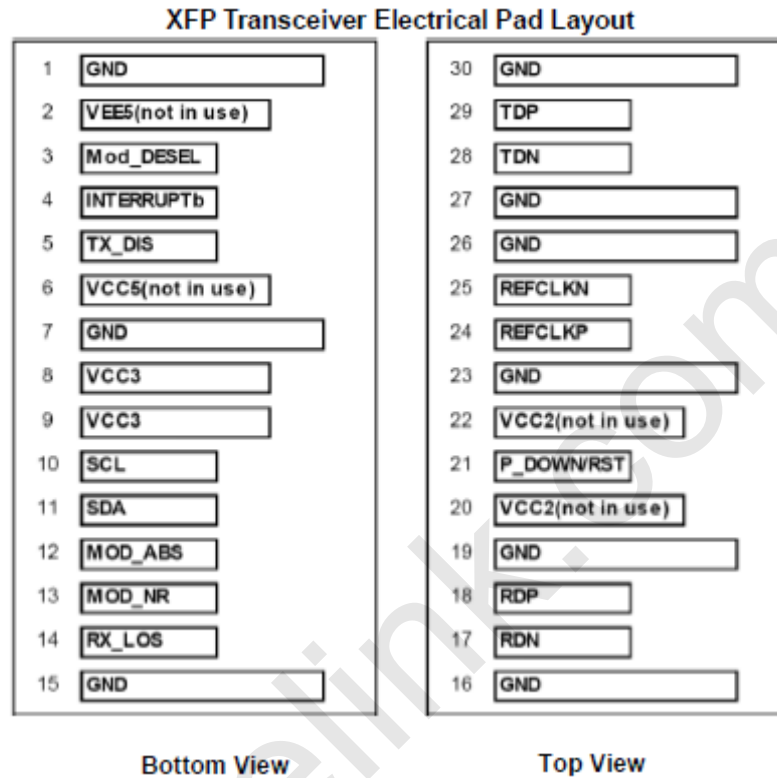

**Figure : Module Interface to Host**

**Pin Descriptions**

Pin#	Name	Logic	Description	Note
1	GND		Module Ground	1
2	VEE5		0.2V Power Supply , not in use	3
3	MOD_DESEL	LVTTTL-I	Module De-select; When held Low allows module to respond to 2-wire serial interface	
4	INTERRUPT	LVTTTL-O	Indicates presence of an important condition, which can be read over the 2-wire serial interface. This pin is an open collector output and must be pulled up to host_Vcc on the host board.	2
5	TX_DIS	LVTTTL-I	Transmitter Disable: When asserted High, transmitter output is turned off. This pin is pulled up to VCC3 in the module	
6	VCC5		+5V Power Supply, not in use	3



**RoHS compliant**  
**TX-1270nm/RX-1330nm Single Fiber Bi-direction XFP Transceiver**  
**10GBASE-BX(Ethernet)**

7	GND		Module Ground	1
8	VCC3		+3.3V Power Supply	
9	VCC3		+3.3V Power Supply	
10	SCL	I/O	2-wire serial interface clock. Host shall resistor connected to host_Vcc of +3.3V.	2
11	SDA	I/O	2-wire serial interface data. Host shall use a pull-up resistor connected to host_Vcc of +3.3V.	2
12	MOD_ABS	LVTTTL-O	Indicates Module is not present. Host shall pull up this pin, and grounded in the module. "High" when the XFP module is absent from a host board.	2
13	MOD_NR	LVTTTL-O	Module not ready; When High, Indicates Module Operational Fault. This pin is an open collector and must be pulled to host_Vcc on the host board.	2,4,5
14	RX_LOS	LVTTTL-O	Receiver Loss of Signal; When high, indicates insufficient optical input power to the module. This pin is an open collector and must be pulled to host_Vcc on the host board.	2
15	GND		Module Ground	
16	GND		Module Ground	
17	RDN	CML-O	Receiver Inverted Data Output; AC coupled inside the module.	
18	RDP	CML-O	Receiver Non-Inverted Data Output; AC coupled in side the module.	
19	GND		Module Ground	1
20	VCC2		+1.8V Power Supply; not in use	3
21	P_DOWN/RST	LVTTTL-I	Power down; When High, module is limited power mode. Low for normal operation. Reset: The falling edge indicates complete reset of the module. This pin is pulled up to VCC3 in the module. (Power Down function)	



**RoHS compliant**  
**TX-1270nm/RX-1330nm Single Fiber Bi-direction XFP Transceiver**  
**10GBASE-BX(Ethernet)**

22	VCC2		+1.8V Power Supply; not in use	3
23	GND		Module Ground	1
24	REFCLKP	PECL-I	Reference clock Non-Inverted Input; not in use	
25	REFCLKN	PECL-I	Reference clock Inverted Input; not in use	
26	GND		Module Ground	1
27	GND		Module Ground	1
28	TDN	CML-I	Transmitter Inverted Data Input; AC coupled inside the module.	
29	TDP	CML-I	Transmitter Non-Inverted Data Input; AC coupled inside the module.	
30	GND		Module Ground	1

**Table 2: XFP Module PIN Definition**

**Notes:**

1. Module ground pins are isolated from the module case and chassis ground within the module.
2. Shall be pulled up with 4.7k to 10k ohm to a voltage between 3.15V and 3.45V on the host board.
3. Not connected internally.
4. Response time: typ. 20msec ( XFP MSA Rev. 4.5 $\leq$ 1msec)



**RoHS compliant**  
**TX-1270nm/RX-1330nm Single Fiber Bi-direction XFP Transceiver**  
**10GBASE-BX(Ethernet)**

**3. TRANSCEIVER BLOCK DIAGRAM**

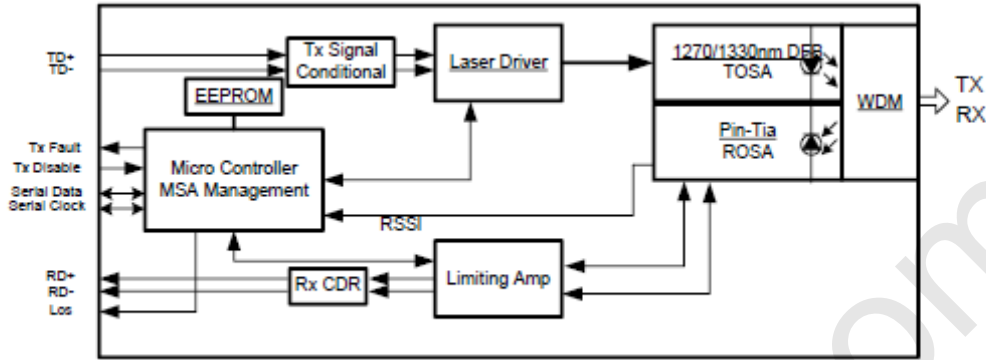

**4. ABSOLUTE MAXIMUM RATING**

These values represent the damage threshold of the module. Stress in excess of any of the individual Absolute Maximum Ratings can cause immediate catastrophic damage to the module even if all other parameters are within Recommended Operating Conditions.

Parameters	Symbol	Min.	Max.	Unit
Power Supply Voltage	VCC	0	3.6	V
Storage Temperature	Tc	-40	85	°C
Operating Case Temperature	Tc	-40	85	°C
Relative Humidity	RH	5	95	%
RX Input Average Power	Pmax	-	0	dBm

**Table : Absolute Maximum Rating**

**5. RECOMMENDED OPERATING ENVIRONMENT**

Recommended Operating Environment specifies parameters for which the electrical and optical characteristics hold unless otherwise noted.

Parameters	Symbol	Min.	Typical	Max	Unit
Power Supply Voltage	VCC	3.135	3.3	3.465	V
Power Supply Current	Icc			300	mA
Operating Case Temperature, N00	TC-N	0	25	70	°C



**RoHS compliant**  
**TX-1270nm/RX-1330nm Single Fiber Bi-direction XFP Transceiver**  
**10GBASE-BX(Ethernet)**

Operating Case Temperature, V00	TC-V	-40	25	85	°C
------------------------------------	------	-----	----	----	----

**Table : Recommended Operating**

**6. OPTICAL CHARACTERISTICS**

The following optical characteristics are defined over the Recommended Operating Environment unless otherwise specified.

Parameters	Unit	Values
Operating Reach	km	70
<b>Transmitter</b>		
Center wavelength (range), CL-XFP-70-27	nm	1265 -1275
Center wavelength (range), CL-XFP-70-33	nm	1325 -1335
Side Mode Suppression Ratio (min)	dB	30
Launched power		
– maximum (Average)	dBm	+7
– minimum (Average)	dBm	+3
Transmitter and dispersion penalty (max)	dB	3.2
Average launch power of OFF transmitter (max)	dBm	-30
Extinction ratio (min)	dB	3.5
RIN12 OMA (max)	dB/Hz	-128
Optical Return Loss Tolerance (min)	dB	12
<b>Receiver</b>		
Center wavelength (range), CL-XFP-70-27	nm	1320 -1350
Center wavelength (range), CL-XFP-70-33	nm	1250 -1280
Receive overload (min) in average power(note 1)	dBm	-7
Receive sensitivity (max) in average power(note 1)	dBm	-23
Receiver Reflectance (max)	dB	-12
Vertical eye closure penalty (min)(note 3)	dB	2.2
Los Assert(min)	dBm	-39
Los Dessert(max)	dBm	-22
Los Hysteresis(min)	dB	0.5
Stressed eye jitter (min)(note 2)	Ulp-p	0.3



**RoHS compliant**  
**TX-1270nm/RX-1330nm Single Fiber Bi-direction XFP Transceiver**  
**10GBASE-BX(Ethernet)**

Receive electrical 3dB upper cutoff frequency (max)	GHz	12.3
Receiver power (damage, Max)	dBm	-5

**Notes:**

1. Average optical power shall be measured using the methods specified in TIA/EIA-455-95.
2. Receiver sensitivity is informative. Stressed receiver sensitivity shall be measured with conformance test signal for BER =  $1 \times 10^{-12}$
3. Vertical eye closure penalty and stressed eye jitter are the test conditions for measuring stressed receiver sensitivity. They are not the required characteristic of the receiver.
4. Power budget is defined as the different between the Rx sensitivity and the Tx output power of the interface.
5. Path penalty is intended as the power penalty of the interface between back-to-back and the maximum applied dispersion.

## 7. DIGITAL DIAGNOSTIC FUNCTIONS

The following digital diagnostic characteristics are defined over the Recommended Operating Environment unless otherwise specified. It is compliant to SFF8472 Rev10.2 with internal calibration mode. For external calibration mode please contact our sales staff.

Parameter	Symbol	Min.	Max	Unit	Notes
Temperature monitor absolute error	DMI_Temp	-3	3	degC	Over operating temp
Laser power monitor absolute error	DMI_TX	-3	3	dB	
RX power monitor absolute error	DMI_RX	-3	3	dB	-1dBm to -15dBm range
Supply voltage monitor absolute error	DMI_VCC	-0.08	0.08	V	Full operating range
Bias current monitor	DMI_Ibias	-10%	10%	mA	

**Table : Digital Diagnostic Specification Table**





**RoHS compliant**  
**TX-1270nm/RX-1330nm Single Fiber Bi-direction XFP Transceiver**  
**10GBASE-BX(Ethernet)**

**8. Recommended Power Supply Filter**

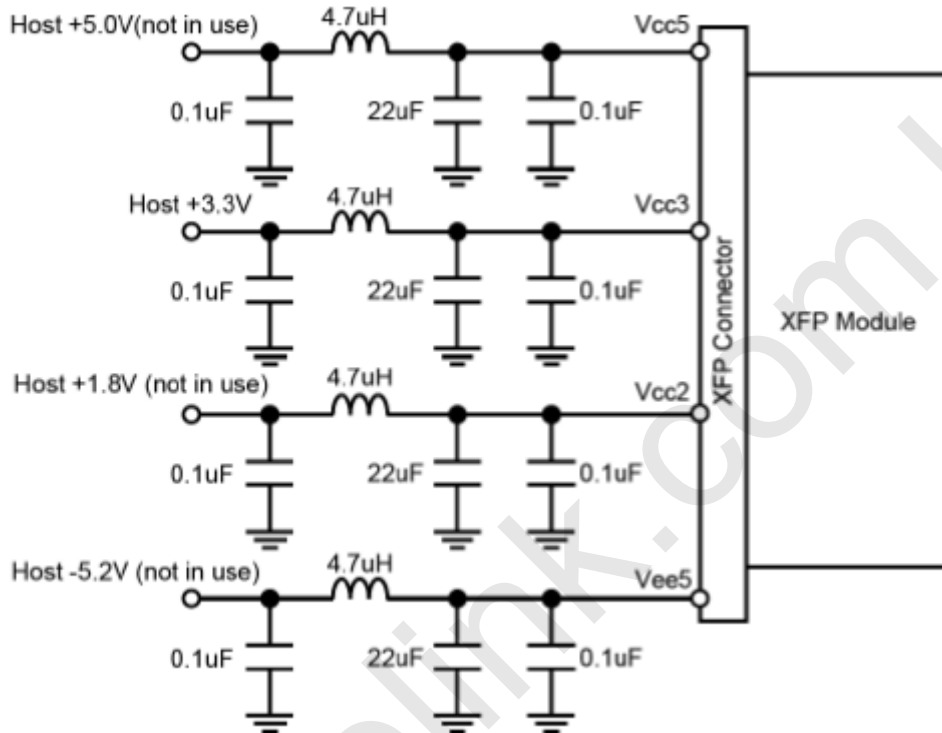

**Recommended Electrical Interface to Host**

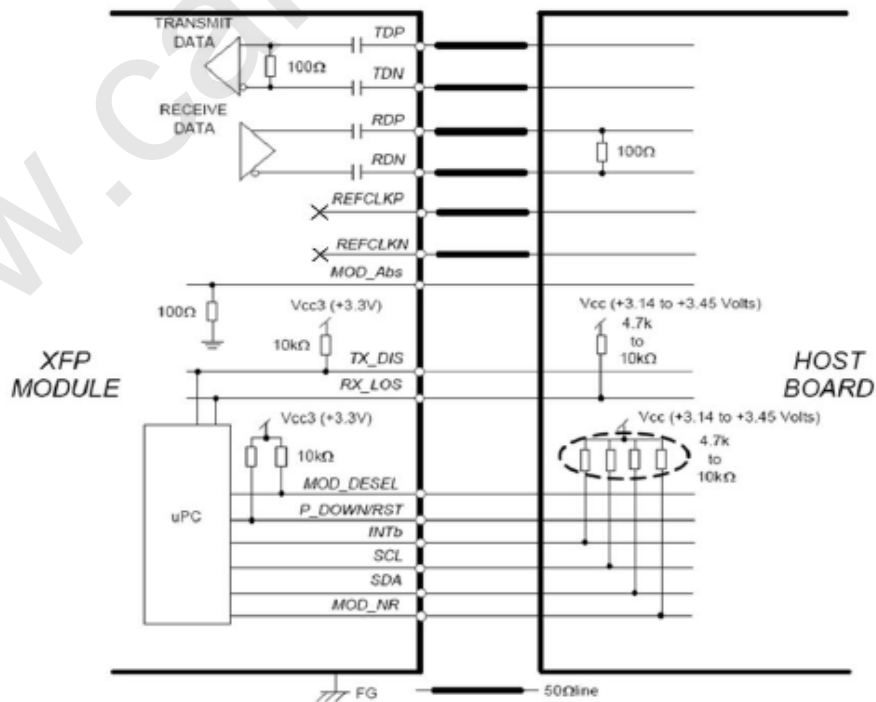



**RoHS compliant**  
**TX-1270nm/RX-1330nm Single Fiber Bi-direction XFP Transceiver**  
**10GBASE-BX(Ethernet)**

**9. MSA Compliant EEPROM Structure**

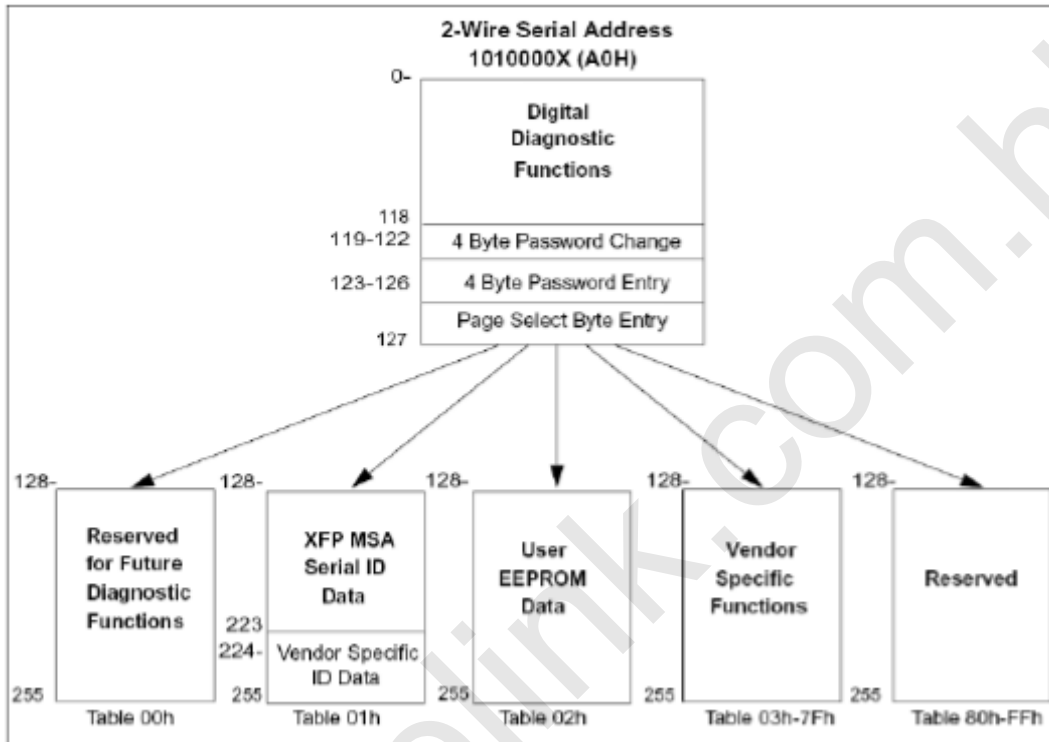

**10. ESD**

This transceiver is specified as ESD threshold 2kV for all electrical input pins, tested per MIL-STD-883, Method 3015.4 /JESD22-A114-A (HBM). However, normal ESD precautions are still required during the handling of this module. This transceiver is shipped in ESD protective packaging. It should be removed from the packaging and handled only in an ESD protected environment.

**11. LASER SAFTY**

This is a Class 1 Laser Product according to IEC 60825-1:1993+A1:1997+A2:2001. This product complies with 21 CFR 1040.10 and 1040.11 except for deviations pursuant to Laser Notice No. 50, dated (July 26, 2001)