



**RoHS compliant**  
**TX-1330nm/RX-1270nm Single Fiber Bi-direction XFP Transceiver**  
**10GBASE-BX(Ethernet)**



### Features

- Compliant with IEEE802.3ae 10GBASE-BX
- Ethernet standard
- Bi-Direction link distance up to 20km
- Simplex LC connector
- Power consumption<1.5W
- Compliant with XFP MSA INF-8077i
- Differential LVPECL inputs and CML outputs
- Single power supply 3.3V
- TTL signal detect indicator
- Hot Pluggable
- Class 1 laser product complies with EN 60825-1

### Ordering Information

| PART NUMBER   | INPUT/OUTPUT | SIGNAL DETECT | VOLTAGE | TEMPERATURE    |
|---------------|--------------|---------------|---------|----------------|
| CL-XFP-20-33  | AC/AC        | TTL           | 3.3V    | -10°C to 70 °C |
| CL-XFP-20-33e | AC/AC        | TTL           | 3.3V    | -30°C to 70 °C |
| CL-XFP-20-33i | AC/AC        | TTL           | 3.3V    | -40°C to 85 °C |

### Absolute Maximum Ratings

| PARAMETER           | SYMBOL    | MIN  | MAX      | UNITS | NOTE |
|---------------------|-----------|------|----------|-------|------|
| Storage Temperature | $T_s$     | -40  | 85       | °C    |      |
| Supply Voltage      | $V_{cc3}$ | -0.5 | 4.0      | V     |      |
| Input Voltage       | $V_{IN}$  | -0.5 | $V_{cc}$ | V     |      |



RoHS compliant  
TX-1330nm/RX-1270nm Single Fiber Bi-direction XFP Transceiver  
10GBASE-BX(Ethernet)

### Recommended Operating Conditions

| PARAMETER                  | SYMBOL            | MIN | MAX | UNITS | NOTE  |
|----------------------------|-------------------|-----|-----|-------|---|
| Case Operating Temperature | $T_c$             | -5  | 70  | °C    | $T_c = -5^{\circ}\text{C}$ to $70^{\circ}\text{C}$  |
|                            | $T_e$             | -30 | 70  | °C    | $T_c = -30^{\circ}\text{C}$ to $70^{\circ}\text{C}$ |
|                            | $T_i$             | -40 | 85  | °C    | $T_c = -40^{\circ}\text{C}$ to $85^{\circ}\text{C}$ |
| Supply Voltage             | $V_{cc}$          | 3.1 | 3.5 | V     |   |
| Supply Current             | $I_{TX} + I_{RX}$ | --- | 600 | mA    |   |

### Monitoring Specification

| Data Address | PARAMETER    | RANGE                       | ACCURACY                |
|--------------|--------------|-----------------------------|-------------------------|
| 96-97        | Temperature  | -10 to $90^{\circ}\text{C}$ | $\pm 3^{\circ}\text{C}$ |
| 100-101      | Bias Current | 0 to 100mA                  | $\pm 10\%$              |
| 102-103      | TX Power     | -4 to +5dBm                 | $\pm 2\text{dB}$        |
| 104-105      | RX Power     | -16 to 1.5dBm               | $\pm 2\text{dB}$        |
| 106-107      | Vcc3 Voltage | 3.0~3.6Volts                | $\pm 3\%$               |

### Transmitter Electro-optical Characteristics

$V_{cc} = 3.1\text{ V}$  to  $3.5\text{ V}$ ,  $T_c = -10^{\circ}\text{C}$  to  $70^{\circ}\text{C}$  for CL-XFP-20-33  
&  $T_c = -40^{\circ}\text{C}$  to  $85^{\circ}\text{C}$  for CL-XFP-20-33i



RoHS compliant  
 TX-1330nm/RX-1270nm Single Fiber Bi-direction XFP Transceiver  
 10GBASE-BX(Ethernet)

| PARAMETER                              | SYMBOL            | MIN                        | TYP. | MAX      | UNITS   | NOTE |
|--|-------------------|----------------------------|------|----------|---------|------|
| Operating Data Rate                    |                   | 9.95                       |      | 11.3     | Gbps    |      |
| Input Reference Clock Rate             |                   | Not Required               |      |          |         |      |
| Output power                           | $P_{OUT}$         | -2                         |      | +3       | dBm     |      |
| Extinction Ratio                       | $ER$              | 3.5                        |      |          | dB      |      |
| Center Wavelength                      | $\lambda_C$       | 1320                       |      | 1340     | nm      |      |
| Sidemode Suppression ratio             | $SSR_{min}$       | 30                         |      |          | dB      |      |
| The transmitter and dispersion penalty | $Tdp$             |                            |      | 3.2      | dB      |      |
| Relative Intensity Noise               | $RIN$             | ---                        | ---  | -128     | dB/Hz   |      |
| Output Eye                             |                   | Compliant with IEEE802.3ae |      |          |         |      |
| Differential Input Voltage             | $V_{DIFF}$        | 0.25                       | ---  | 1.0      | V       |      |
| Transmit Fault Output-Low              | $TX\_FAULT_L$     | 0.0                        | ---  | 0.5      | V       |      |
| Transmit Fault Output-High             | $TX\_FAULT_H$     | 2.4                        | ---  | $V_{CC}$ | V       |      |
| TX_DISABLE Assert Time                 | $t_{off}$         | ---                        | ---  | 10       | $\mu s$ |      |
| TX_DISABLE Negate Time                 | $t_{on}$          | ---                        | ---  | 2        | ms      |      |
| Time to initialize                     | $t_{init}$        | ---                        | ---  | 300      | ms      |      |
| Interrupt assert delay                 | Interrupt_on      | ---                        | ---  | 200      | ms      |      |
| Interrupt negate delay                 | Interrupt_off     | ---                        | ---  | 500      | $\mu s$ |      |
| P_Down/RST assert delay                | P_Down/RS<br>T_on |                            |      | 100      | $\mu s$ |      |
| Mod_NR assert delay                    | Mod_nr_on         |                            |      | 1        | ms      |      |
| Mod_NR negate delay                    | Mod_nr_off        |                            |      | 1        | ms      |      |
| P-Down reset time                      |                   | 10                         |      |          | $\mu s$ |      |
| RX_LOS assert delay                    | t_loss_on         |                            |      | 100      | $\mu s$ |      |
| RX_LOS negate delay                    | t_loss_off        |                            |      | 100      | $\mu s$ |      |



RoHS compliant  
 TX-1330nm/RX-1270nm Single Fiber Bi-direction XFP Transceiver  
 10GBASE-BX(Ethernet)

Receiver Electro-optical Characteristics

$V_{cc} = 3.1\text{ V to }3.5\text{ V}$ ,  $T_c = 10^\circ\text{C to }70^\circ\text{C}$  for CL-XFP-20-33&  $T_c = -40^\circ\text{C to }85^\circ\text{C}$  for CL-XFP-20-33i

| PARAMETER                                       | SYMBOL          | MIN  | TYP. | MAX      | UNITS         | NOTE             |
|---|-----------------|------|------|----------|---------------|------------------|
| Receiver Overload                               |                 | 0.5  |      |          | dBm           | BER < $10^{-12}$ |
| Receiver Sensitivity                            |                 |      |      | -14      | dBm           | BER < $10^{-12}$ |
| Operating Center Wavelength                     | $\lambda_c$     | 1260 | ---  | 1280     | nm            |                  |
| Optical Return Loss                             | ORL             | 14   | ---  | ---      | dB            |                  |
| Loss of Signal-Asserted                         | $P_A$           | ---  | ---  | -30      | dBm           |                  |
| Loss of Signal-Deasserted                       | $P_D$           | -18  | ---  | ---      | dBm           |                  |
| Differential Output Voltage                     | $V_{DIFF}$      | 0.5  | 0.65 | 0.8      | V             |                  |
| TTL Input High Voltage                          |                 | 2    |      | $V_{cc}$ | V             |                  |
| TTL Input Low Voltage                           |                 | 0    |      | 0.8      | V             |                  |
| TTL Output High Voltage                         |                 | 2.4  | ---  | $V_{cc}$ | V             |                  |
| TTL Output Low Voltage                          |                 | 0    | ---  | 0.4      | V             |                  |
| Receiver Loss of Signal Assert Time (off to on) | $t_{A,RX\_LOS}$ | ---  | ---  | 100      | $\mu\text{s}$ |                  |
| Receiver Loss of Signal Assert Time (on to off) | $t_{D,RX\_LOS}$ | ---  | ---  | 100      | $\mu\text{s}$ |                  |



**RoHS compliant**  
**TX-1330nm/RX-1270nm Single Fiber Bi-direction XFP Transceiver**  
**10GBASE-BX(Ethernet)**

---

[www.carelink.com.hk](http://www.carelink.com.hk)



RoHS compliant  
 TX-1330nm/RX-1270nm Single Fiber Bi-direction XFP Transceiver  
 10GBASE-BX(Ethernet)

Serial ID Memory Contents (Table 01h)

| Address   | Size | Name            | Hex  | Description   |
|-----------|------|-----------------|--|---|
| 128       | 1    | Identifier      | 06   | XFP   |
| 129       | 1    | Ext. Identifier | 10   | Power consumption<1.5W<br>Tx reference clock not required |
| 130       | 1    | Connector       | 07   | LC Connector  |
| 131-138   | 8    | Transceiver     | 44 40 00 00 00 00 00 00                            | 10G BASE-LR/LW<br>10GFC 1200-SM-LL-L                      |
| 139       | 1    | Encoding        | D0   | 64B/66B<br>8B10B<br>NRZ                                   |
| 140       | 1    | BR-Min          | 63   | 9.95Gbps  |
| 141       | 1    | BR-Max          | 71   | 11.3Gbps  |
| 142       | 1    | Length(SMF)-km  | 0A   | 20km  |
| 143       | 1    | Length(E-50um)  | 00   | 0   |
| 144       | 1    | Length(50um)    | 00   | 0   |
| 145       | 1    | Length(62.5um)  | 00   | 0   |
| 146       | 1    | Length(copper)  | 00   | 0   |
| 147       | 1    | Device Tech     | 40   | Uncooled DFB, PIN detector                                |
| 148-163   | 16   | Vendor name     | 43 61 72 65 6c 69 6e 6b<br>20 20 20 20 20 20 20 20 | Carelink  |
| 164       | 1    | CDR support     | F8   | 9.95~11.3Gbps   |
| 165-167   | 3    | Vender OUI      | 00 00 00   |   |
| 16168-183 |      | Vendor PN       | 43 4c 20 58 46 50 20 32<br>30 2d 32 33 00 00 00 00 | CL-XFP-20-27  |
|           |      |                 | 43 4c 20 58 46 50 20 32<br>30 2d 32 33 00 00 00 00 | CL-XFP-20-27i   |
| 184-185   | 2    | Vender rev      | xx xx  |   |
| 186-187   | 2    | Wavelength      | 67 E8  | 1330nm  |



**RoHS compliant**  
**TX-1330nm/RX-1270nm Single Fiber Bi-direction XFP Transceiver**  
**10GBASE-BX(Ethernet)**

|         |    |                            |                         |  |
|---------|----|----------------------------|-------------------------|--|
| 188-189 | 2  | Wavelength Tolerance       | 07 D0                   | +/- 10nm   |
|         | 1  | Max Case Temp              | 46                      | 70degC   |
|         |    |                            | 55                      | 85degC   |
| 191     | 1  | CC_BASE                    |                         | Check code(128~190)  |
| 192-195 | 4  | Power Supply               | 4B 64 05 00             | 1.5W (power consumption)<br>1W (power down mode)<br>500mA (3.3V) |
| 196-211 | 16 | Vender SN                  |                         | ASCII  |
| 212-219 | 8  | Vender date code           | xx xx xx xx xx xx 20 20 | ASCII Year(2bytes) ,<br>Month(2bytes) , Day(2bytes)              |
| 220     | 1  | Diagnostic Monitoring Type | 08                      | No BER support; Average Power                                    |
| 221     | 1  | Enhanced Options           | 60                      | Optional soft Tx_disable and P_down                              |
| 222     | 1  | Aux Monitoring             | 70                      | AUX1:+3.3V power supply  |
| 223     | 1  | CC_EXT                     |                         | Check code(192~222)  |
| 224-255 | 32 | Vendor specific            |                         | Reserved   |



**RoHS compliant**  
**TX-1330nm/RX-1270nm Single Fiber Bi-direction XFP Transceiver**  
**10GBASE-BX(Ethernet)**

**Block Diagram of Transceiver**

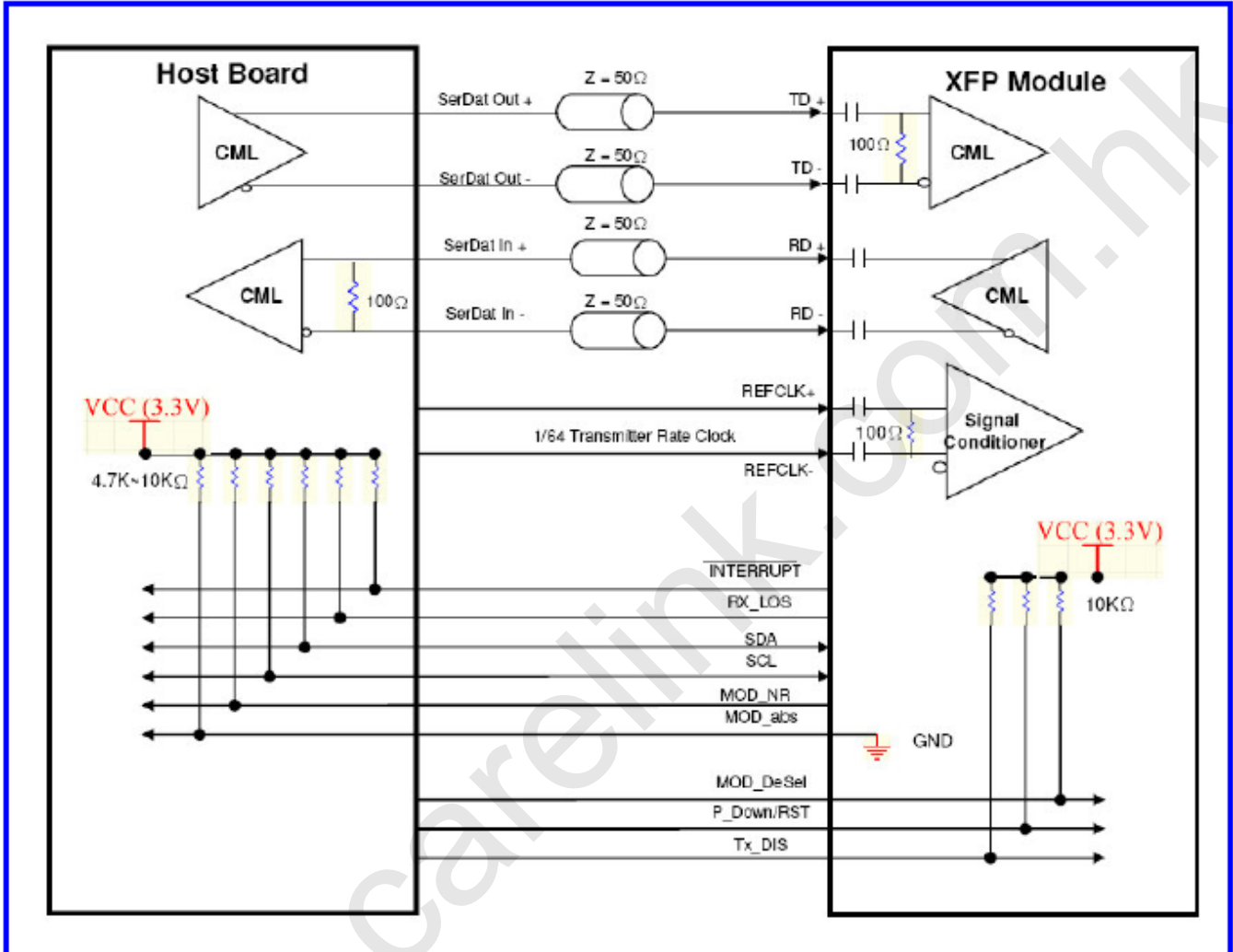

**MOD\_NR**

The Mod\_NR is an output pin that when High, indicates that the module has detected a condition that renders transmitter and or receiver data invalid, shall consist of logical OR of the following signals:

- Transmit Signal Conditioner Loss of Lock
- Transmitter Laser Fault
- Receiver Signal Conditioner Loss of Lock





**RoHS compliant**  
**TX-1330nm/RX-1270nm Single Fiber Bi-direction XFP Transceiver**  
**10GBASE-BX(Ethernet)**

---

### **MOD\_DESEL**

The Mod\_DeSel is an input pin. When held Low by the host, the module responds to 2-wire serial communication commands. The Mod\_DeSel allows the use of multiple XFP modules on a single 2-wire interface bus. When the Mod\_DeSel pin is “High”, the module shall not respond to or acknowledge any 2-wire interface communication from the host.

### **INTERRUPT**

Interrupt is an output pin. When “Low”, indicates possible module operational fault or a status critical to the host system.

### **TX\_DIS**

TX\_DIS is an input pin. When TX\_DIS is asserted High, the XFP module transmitter output must be turned off.

### **MOD\_ABS**

Mod\_ABS is pulled up to Host\_Vcc on the host board and grounded in the XFP module. Mod\_ABS is then asserted “High” when the XFP module is physically absent from a host slot.

### **RX\_LOS**

The RX\_LOS when High indicates insufficient optical power for reliable signal reception.

### **P\_Down/RST**

This is a multifunction pin for module Power Down and Reset. The P\_Down/RST pin must be pulled up to VCC3 in the XFP module.

### **POWER DOWN FUNCTION**

The P\_Down pin, when held High by the host, places the module in the standby (Low Power) mode with a maximum power dissipation of 1.5W. This protects hosts which are not capable of cooling higher power modules which may be accidentally inserted.



RoHS compliant  
TX-1330nm/RX-1270nm Single Fiber Bi-direction XFP Transceiver  
10GBASE-BX(Ethernet)

### Dimensions

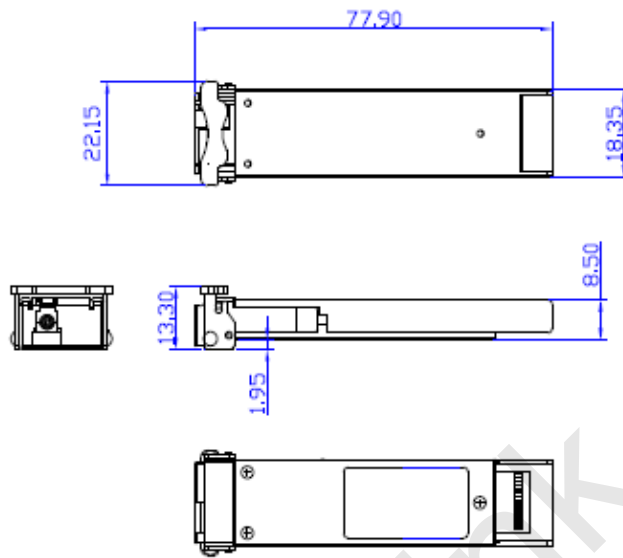

**DIMENSIONS ARE IN MILLIMETERS**

**ALL DIMENSIONS ARE  $\pm 0.2\text{mm}$  UNLESS OTHERWISE SPECIFIED**



RoHS compliant  
TX-1330nm/RX-1270nm Single Fiber Bi-direction XFP Transceiver  
10GBASE-BX(Ethernet)

Pin Assignment

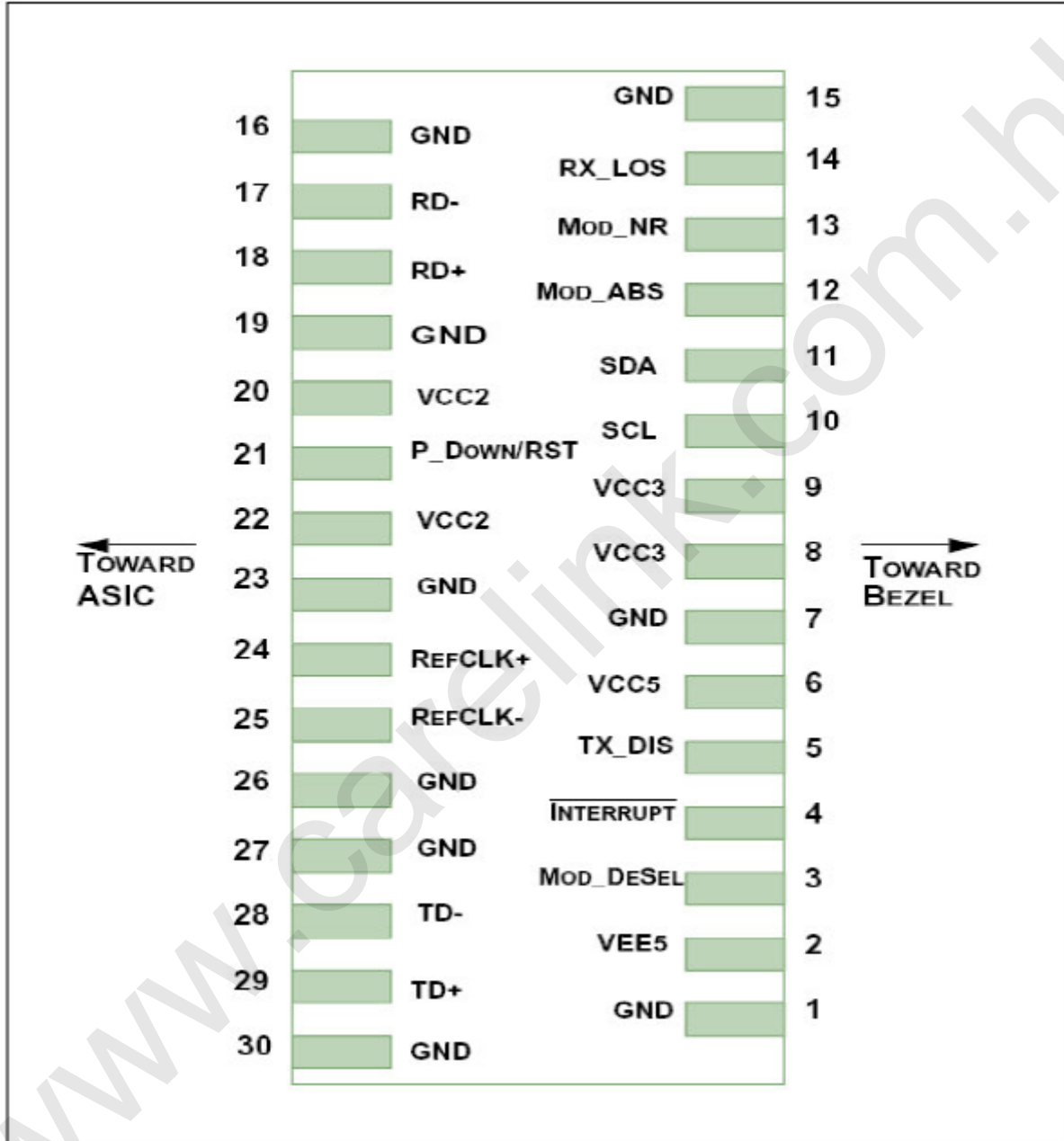



**RoHS compliant**  
**TX-1330nm/RX-1270nm Single Fiber Bi-direction XFP Transceiver**  
**10GBASE-BX(Ethernet)**

| <i>Pin</i> | <i>Logic</i> | <i>Symbol</i> | <i>Name/Description</i>   | <i>Note</i> |
|------------|--------------|---------------|---|-------------|
| 1          |              | GND           | Module Ground   | 1           |
| 2          |              | VEE5          | Optional -5.2V Power Supply   |             |
| 3          | LVTTL-I      | Mod_DeSel     | Module De-select; When held low allows module to respond to 2-wire serial interface   |             |
| 4          | LVTTL-O      | Interrupt     | Interrupt; Indicates presence of an important condition which can be read over the 2-wire serial interface  | 2           |
| 5          | LVTTL-I      | TX_DIS        | Transmitter Disable; Turns off transmitter laser output   |             |
| 6          |              | VCC5          | +5V Power Supply  |             |
| 7          |              | GND           | Module Ground   | 1           |
| 8          |              | VCC3          | +3.3V Power Supply  |             |
| 9          |              | VCC3          | +3.3V Power Supply  |             |
| 10         | LVTTL-I/O    | SCL           | 2-Wire Serial Interface Clock   | 2           |
| 11         | LVTTL-I/O    | SDA           | 2-Wire Serial Interface Data Line   | 2           |
| 12         | LVTTL-O      | Mod_Abs       | Indicates Module is not present. Grounded in the Module   | 2           |
| 13         | LVTTL-O      | Mod_NR        | Module Not Ready; Indicating Module Operational Fault   | 2           |
| 14         | LVTTL-O      | RX_LOS        | Receiver Loss Of Signal Indicator   | 2           |
| 15         |              | GND           | Module Ground   | 1           |
| 16         |              | GND           | Module Ground   | 1           |
| 17         | CML-O        | RD-           | Receiver Inverted Data Output   |             |
| 18         | CML-O        | RD+           | Receiver Non-Inverted Data Output   |             |
| 19         |              | GND           | Module Ground   | 1           |
| 20         |              | VCC2          | +1.8V Power Supply  | 3           |
| 21         | LVTTL-I      | P_Down/RST    | Power down; When high, requires the module to limit power consumption to 1.5W or below. 2-Wire serial interface must be functional in the low power mode.<br>Reset; The falling edge initiates a complete reset of the module including the 2-wire serial interface, equivalent to a power cycle. |             |
| 22         |              | VCC2          | +1.8V Power Supply  | 3           |
| 23         |              | GND           | Module Ground   | 1           |
| 24         | PECL-I       | RefCLK+       | Reference Clock Non-Inverted Input, AC coupled on the host board  |             |
| 25         | PECL-I       | RefCLK-       | Reference Clock Inverted Input, AC coupled on the host board  |             |
| 26         |              | GND           | Module Ground   | 1           |
| 27         |              | GND           | Module Ground   | 1           |
| 28         | CML-I        | TD-           | Transmitter Inverted Data Input   |             |
| 29         | CML-I        | TD+           | Transmitter Non-Inverted Data Input   |             |
| 30         |              | GND           | Module Ground   | 1           |

1. Module ground pins Gnd are isolated from the module case and chassis ground within the module.  
2. Shall be pulled up with 4.7K-10Kohms to a voltage between 3.15V and 3.45V on the host board.  
3. The 1.8 V power supply can be optionally programmed to voltages lower than 1.8 V in modules supporting the variable power supply.



**RoHS compliant**  
**TX-1330nm/RX-1270nm Single Fiber Bi-direction XFP Transceiver**  
**10GBASE-BX(Ethernet)**

**Regulatory Compliance**

| Feature                            | Reference  | Performance               |
|------------------------------------|--|---------------------------|
| Electrostatic discharge (ESD)      | IEC/EN 61000-4-2                                 | Compatible with standards |
| Electromagnetic Interference (EMI) | FCC Part 15 Class B EN 55022 Class B (CISPR 22A) | Compatible with standards |
| Laser Eye Safety                   | FDA 21CFR 1040.10, 1040.11 IEC/EN 60825-1, 2     | Class 1 laser product     |
| Component Recognition              | IEC/EN 60950 , UL                                | Compatible with standards |
| ROHS                               | 2002/95/EC                                       | Compatible with standards |
| EMC                                | EN61000-3  | Compatible with standards |

**Eye Safety Mark**

|   |   |
|---|---|
| <p>The LS3 series single-mode transceiver is a class 1 laser product. It complies with EN 60825-1 and FDA 21 CFR 1040.10 and 1040.11. In order to meet laser safety requirements the transceiver shall be operated within the Absolute Maximum Ratings.</p> <p><b><u>Caution</u></b><br/>All adjustments have been done at the factory before the shipment of the devices. No maintenance and user serviceable part is required. Tampering with and modifying the performance of the device will result in voided product warranty.</p> | <p><b><u>Required Mark</u></b></p> <div style="border: 1px solid black; padding: 5px; text-align: center;"><p><b>Class 1 Laser Product</b><br/><b>Complies with</b><br/><b>21 CFR 1040.10 and 1040.11</b></p></div> |
|---|---|

Note : All information contained in this document is subject to change without notice.