

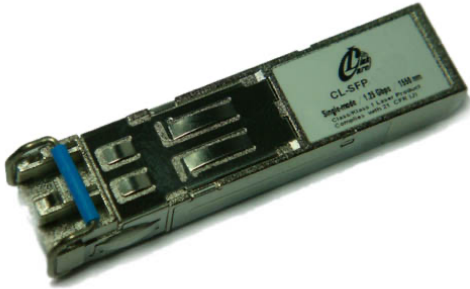

**RoHS compliant
Small Form Pluggable (SFP+)
SFP+ CWDM 80KM Optical Transceivers**



Features

- Compliant with SFF-8431, SFF-8432 and IEEE802.3ae
- 10GBASE-ER, and 2G/4G/ 8G/10G Fiber Channel applications.
- Wavelength selectable to ITU-T standards covering CWDM grid wavelengths
- Cooled EML transmitter and PIN receiver
- link length up to 80km
- Low Power Dissipation 1.5W Maximum
- -5°C to 70°C Operating Case Temperature
- Single 3.3V power supply
- Diagnostic Performance Monitoring of module temperature, supply
- Voltages, laser bias current, transmit optical power, receive optical power
- RoHS compliant and lead free

Applications

- 10GBASE-ER (with/without FEC)
- 10G Fiber Channel (with/without FEC)

Ordering Information

PART NUMBER	TX/RX	INPUT/OUTPUT	SIGNAL DETECT	TEMPERATURE	PACKAGE	Distance
CL-SFP+_C80-XX		AC/AC	TTL	-5°C to 70 °C	LC SFP +	80km
CL-SFP+_C80-XXe		AC/AC	TTL	-30°C to 70 °C	LC SFP +	80km
CL-SFP+_C80-XXi		AC/AC	TTL	-40°C to 85 °C	LC SFP +	80km



RoHS compliant
Small Form Pluggable (SFP+)
SFP+ CWDM 80KM Optical Transceivers

Description

Carelink SFP+ZR CWDM Transceiver is a “Limiting module”, designed for 10GBASE-ER, and 2G/4G/8G/10G Fiber- Channel applications.

The transceiver consists of two sections: The transmitter section incorporates a colded EML laser. And the receiver section consists of a PIN photodiode integrated with a TIA. All modules satisfy class I laser safety requirements. Digital diagnostics functions are available via a 2-wire serial interface, as specified in SFF-8472, which allows real-time access to device operating parameters such as transceiver temperature, laser bias current, transmitted optical power, received optical power and transceiver supply voltage.

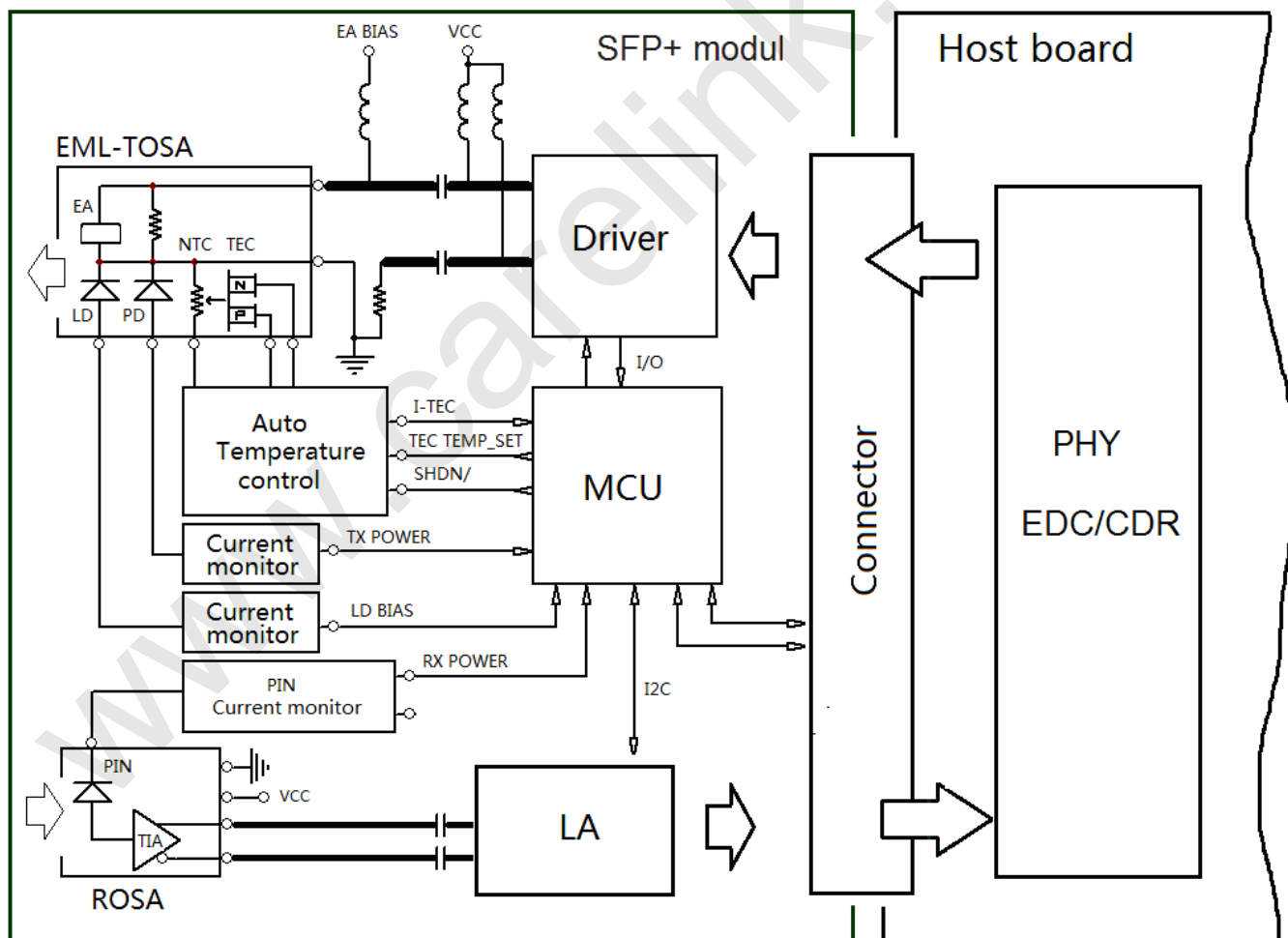

Figure1. Module Block Diagram



RoHS compliant
Small Form Pluggable (SFP+)
SFP+ CWDM 80KM Optical Transceivers

Absolute Maximum Ratings

Parameter	Symbol	Min	Max	Unit
Supply Voltage	Vcc	-0.5	3.8	V
Storage Temperature	Tst	-40	85	°C
Relative Humidity	Rh	0	85	%

Operating Conditions

Parameter	Symbol	Min	Typical	Max	Unit
Supply Voltage	Vcc	3.13	3.3	3.47	V
Supply current1]	Icc	-	420	610	mA
Operating Case temperature	Tca	-5	-	70	°C
Module Power Dissipation	Pm	-	1.4	2	W

Transmitter Specifications – Optical

Parameter	Symbol	Min	Typical	Max	Unit
Center Wavelength	λ_c	1464.5		1617.5	nm
Center wavelength stability	$\Delta\lambda_D$	-6.5	λ_c	6.5	nm
Spectral Width (-20dB)	$\Delta\lambda_{20}$	-	-	0.3	nm
Average Optical Power	Po	0	-	+3	dBm
Side Mode Suppression Ratio	SMSR	30	-	-	dB
Optical Transmit Power (disabled)	PTX_DISABLE	-	-	-30	dBm
Extinction Ratio	ER	9	-	-	dB
Relative Intensity Noise	RIN	-	-	-128	dB/Hz
Optical Return Loss Tolerance	Orl	-	-	21	dB



RoHS compliant
Small Form Pluggable (SFP+)
SFP+ CWDM 80KM Optical Transceivers

Receiver Specifications – Optical

Parameter	Symbol	Min	Typical	Max	Unit
Input Operating Wavelength	λ	1260	-	1620	nm
Receiver sensitivity(Average) [1]	Rsen	-	-	-24	dBm
Maximum Input Power	RX-overload	-	-	-7	dBm
Loss of Signal Asserted	Lsa	-34	-	-	dBm
LOS De-Asserted	Lda	-	-	-24	dBm
LOS Hysteresis	Lh	0.5	-	-	dB

Notes:

[1] Measured with conformance test signal for BER = 10^{-12} . The stressed sensitivity values in the table are for system level BER measurements which include the effects of CDR circuits. It is recommended that at least 0.4 dB additional margin be allocated if component level measurements are made without the effects of CDR circuits.

Transmitter Specifications – Electrical

Parameter	Symbol	Min	Typical	Max	Unit
Data Rate	Mra	-	10.3	11.3	Gbps
Input differential impedance	Rim	-	100	-	Ω
Differential data Input	VtxDIFF	120	-	850	mV
Transmit Disable Voltage	VD	2.0	-	Vcc3+0.3	V
Transmit Enable Voltage	Ven	0	-	+0.8	V
Transmit Disable Assert Time	Vn	-	-	100	us

Receiver Specifications – Electrical

Parameter	Symbol	Min	Typical	Max	Unit
Data Rate	Mra	-	10.3	11.3	Gbps
Differential Output Swing	Vout P-P	350	-	850	mV
Rise/Fall Time	Tr / Tf	24	-	-	ps
Loss of Signal –Asserted	VOH	2	-	Vcc3+0.3-	V
Loss of Signal –Negated	VOL	0	-	+0.4	V



RoHS compliant
Small Form Pluggable (SFP+)
SFP+ CWDM 80KM Optical Transceivers

Digital Diagnostic Functions

Parameter	Symbol	Min.	Max	Unit	Notes
Accuracy					
Transceiver Temperature	DMI_Temp	-3	+3	degC	Over operating temp
TX Output optical power	DMI_TX	-3	+3	dB	
RX Input optical power	DMI_RX	-3	+3	dB	-3dBm to -12dBm range
Transceiver Supply voltage	DMI_VCC	-0.08	+0.08	V	Full operating range
Bias current monitor	DMI_Ibias	-10%	10%	mA	
Dynamic Range Accuracy					
Transceiver Temperature	DMI_Temp	-5	70	degC	
TX Output optical power	DMI_TX	-1	+2	dBm	
RX Input optical power	DMI_RX	-18	0	dBm	
Transceiver Supply voltage	DMI_VCC	3.0	3.6	V	
Bias current monitor	DMI_Ibias	0	100	mA	



RoHS compliant
 Small Form Pluggable (SFP+)
 SFP+ CWDM 80KM Optical Transceivers

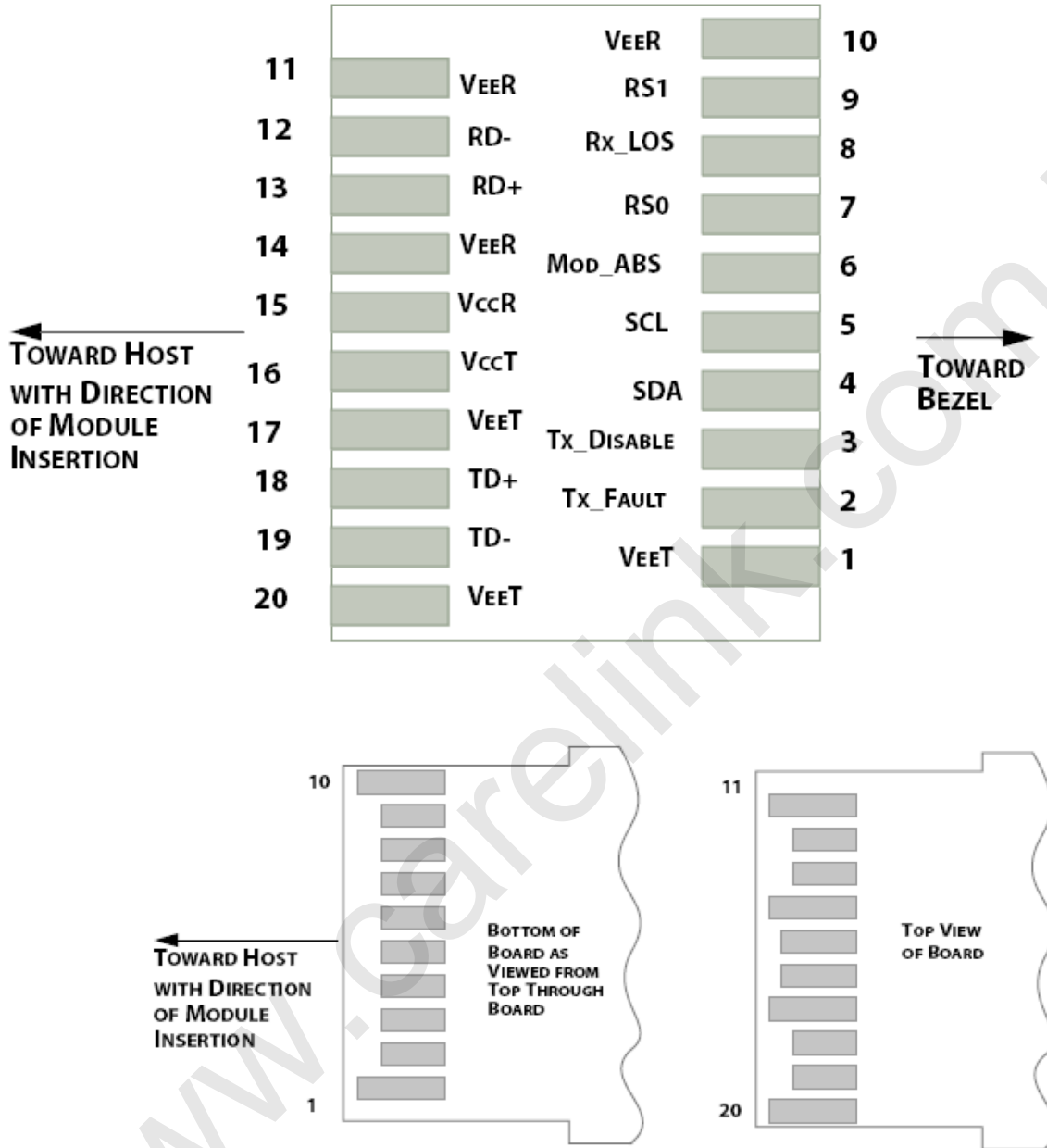

Figure2.Electrical Pin-out Details



RoHS compliant
Small Form Pluggable (SFP+)
SFP+ CWDM 80KM Optical Transceivers

Pin Descriptions

Pin	Symbol	Name/Description
1	VEET [1]	Transmitter Ground
2	Tx_FAULT [2]	Transmitter Fault
3	Tx_DIS [3]	Transmitter Disable. Laser output disabled on high or open
4	SDA [2]	2-wire Serial Interface Data Line
5	SCL [2]	2-wire Serial Interface Clock Line
6	MOD_ABS [4]	Module Absent. Grounded within the module
7	RS0 [5]	Rate Select 0
8	RX_LOS [2]	Loss of Signal indication. Logic 0 indicates normal operation
9	RS1 [5]	Rate Select 1
10	VEER [1]	Receiver Ground
11	VEER [1]	Receiver Ground
12	RD-	Receiver Inverted DATA out. AC Coupled
13	RD+	Receiver DATA out. AC Coupled
14	VEER [1]	Receiver Ground
15	VCCR	Receiver Power Supply
16	VCCT	Transmitter Power Supply
17	VEET [1]	Transmitter Ground
18	TD+	Transmitter DATA in. AC Coupled
19	TD-	Transmitter Inverted DATA in. AC Coupled
20	VEET [1]	Transmitter Ground

Notes:

[1] Module circuit ground is isolated from module chassis ground within the module.

[2].should be pulled up with 4.7k – 10k ohms on host board to a voltage between 3.15V and 3.6V.

[3]Tx_Disable is an input contact with a 4.7 kΩ to 10 kΩ pullup to VccT inside the module.



**RoHS compliant
Small Form Pluggable (SFP+)
SFP+ CWDM 80KM Optical Transceivers**

[4] Mod_ABS is connected to VeeT or VeeR in the SFP+ module. The host may pull this contact up to Vcc_Host with a resistor in the range 4.7 kΩ to 10 kΩ. Mod_ABS is asserted “High” when the SFP+ module is physically absent from a host slot.

[5] RS0 and RS1 are module inputs and are pulled low to VeeT with > 30 kΩ resistors in the module.

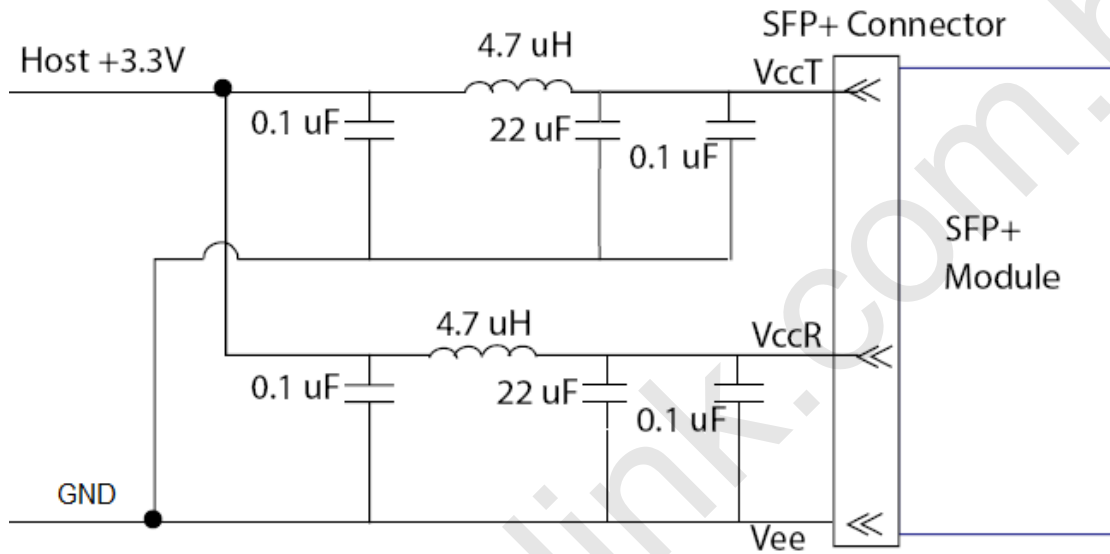

Figure3. Host Board Power Supply Filters Circuit



RoHS compliant
 Small Form Pluggable (SFP+)
 SFP+ CWDM 80KM Optical Transceivers

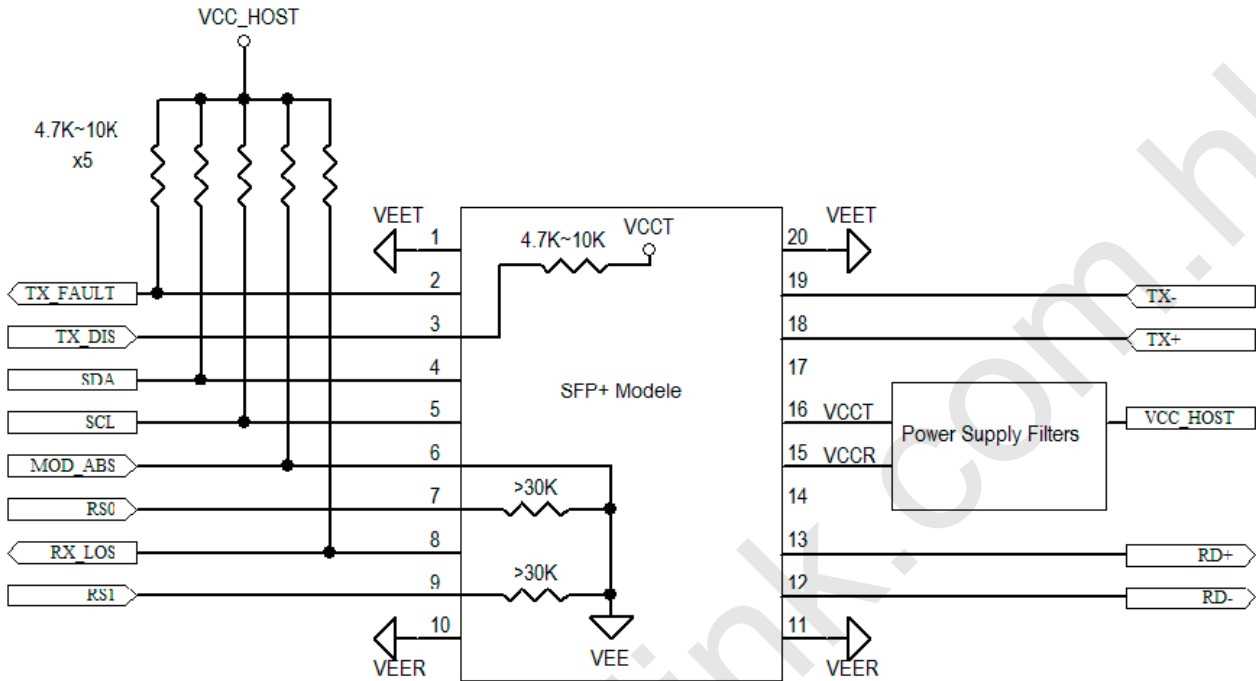

Figure4. Host-Module Interface

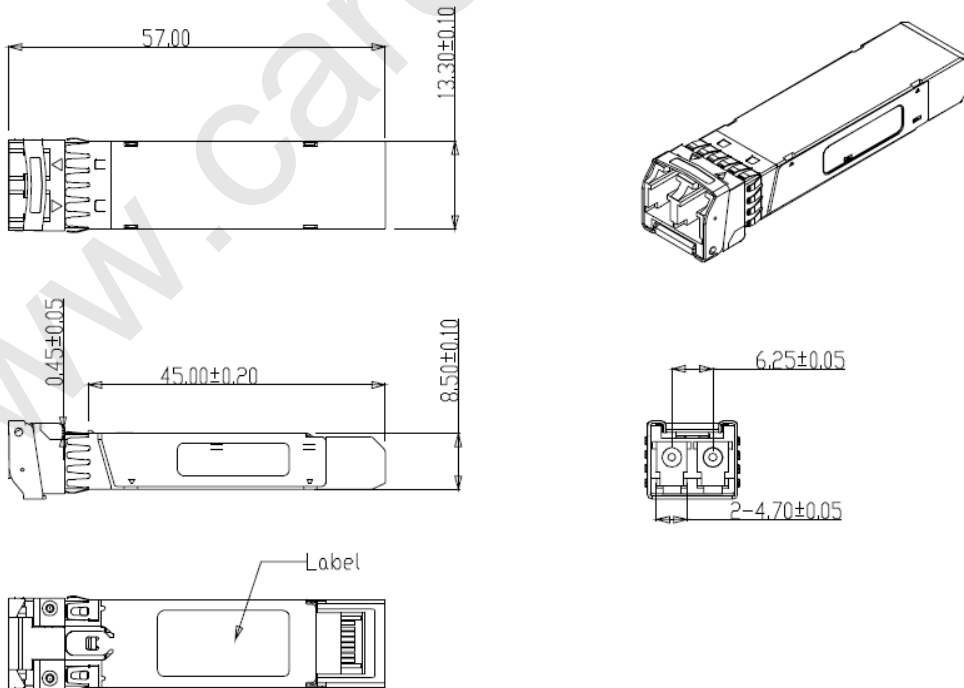

Figure5. Mechanical Specifications



RoHS compliant
Small Form Pluggable (SFP+)
SFP+ CWDM 80KM Optical Transceivers

Regulatory Compliance

Carelink SFP+ transceiver is designed to be Class I Laser safety compliant and is certified per the following standards:

Feature	Agency	Standard	Certificate / Comments
Laser Safety	FDA	CDRH 21 CFR 1040 annd Laser Notice No. 50	1120292-000
Product Safety	UL	UL and CUL EN60950-2:2007	E347511
Environmental protection	SGS	RoHS Directive 2002/95/EC	GZ1001008918/CHEM
EMC	WALTEK	EN 55022:2006+A1:2007	WT10093759-D-E-E

Ordering information

Part Number	Product Description
CL-SFP+_C80-47	10Gbps, 1470nm SFP+ER 80km, -5°C ~ +70°C
CL-SFP+_C80-49	10Gbps, 1490nm SFP+ER 80km, -5°C ~ +70°C
CL-SFP+_C80-51	10Gbps, 1510nm SFP+ER 80km, -5°C ~ +70°C
CL-SFP+_C80-53	10Gbps, 1530nm SFP+ER 80km, -5°C ~ +70°C
CL-SFP+_C80-55	10Gbps, 1550nm SFP+ER 80km, -5°C ~ +70°C
CL-SFP+_C80-57	10Gbps, 1570nm SFP+ER 80km, -5°C ~ +70°C
CL-SFP+_C80-59	10Gbps, 1590nm SFP+ER 80km, -5°C ~ +70°C
CL-SFP+_C80-61	10Gbps, 1610nm SFP+ER 80km, -5°C ~ +70°C



RoHS compliant
Small Form Pluggable (SFP+)
SFP+ CWDM 80KM Optical Transceivers

Eye Safety Mark

The LS3 series single-mode transceiver is a class 1 laser product. It complies with EN 60825-1 and FDA 21 CFR 1040.10 and 1040.11. In order to meet laser safety requirements the transceiver shall be operated within the Absolute Maximum Ratings.

Caution

All adjustments have been done at the factory before the shipment of the devices. No maintenance and user serviceable part is required. Tampering with and modifying the performance of the device will result in voided product warranty.

Required Mark

Class 1 Laser Product
Complies with
21 CFR 1040.10 and 1040.11

Note : All information contained in this document is subject to change without notice.