



RoHS compliant
Small Form Pluggable (SFP+)
SFP+ CWDM 70KM Optical Transceivers



Features

- Hot-Pluggable SFP+Footprint
- 8-WavelengthsCWDM EML Transmitter from1470nm to 1610nm, with step 20nm
- With High Sensitivity APD
- 23dB Power Budget
- Duplex LC connector
- Power Dissipation < 1.5W
- Dispersion tolerance 1600ps/nm
- Case Operation Temperature
- Standard: -5°Cto70°C
- Extended: -20°C~+75°C
- Compliant with SFF-8431 MSA
- Compliant with SFF-8432 MSA
- Compliant with SFF-8472 MSA

Applications

- 10GBASE-ER/EW
- 10G FC
- OBSAI rates 6.144 Gb/s, 3.072 Gb/s, 1.536 Gb/s, 0.768Gb/s
- CPRI rates 10.138Gb/s , 9.830 Gb/s, 7.373Gb/s, 6.144 Gb/s, 4.915 Gb/s, 2.458 Gb/s, 1.229 Gb/s, 0.614Gb/s
- Other optical links

Ordering Information

PART NUMBER	TX/RX	INPUT/OUTPUT	SIGNAL DETECT	TEMPERATURE	PACKAGE	Distance
CL-SFP+23C-L2-XX		AC/AC	TTL	-5°C to 70 °C	LC SFP +	70km
CL-SFP+23C-L2-XXi		AC/AC	TTL	-40°C to 85 °C	LC SFP +	70km



RoHS compliant
Small Form Pluggable (SFP+)
SFP+ CWDM 70KM Optical Transceivers

CWDM* Wavelength

Band	Nomenclature	Wavelength(nm)		
		Min.	Typ.	Max.
S-band Short Wavelength	L2	1464	1470	1477.5
		1484	1490	1497.5
		1504	1510	1517.5
		1524	1530	1537.5
C-band Conventional		1544	1550	1557.5
L-band Long Wavelength		1564	1570	1577.5
		1584	1590	1597.5
		1604	1610	1617.5

CWDM*: 8 Wavelengths from 1470nm to 1610nm, each step 20nm.

Regulatory Compliance

Product Certificate	Certificate Number	Applicable Standard
TUV	R50135086	EN 60950-1:2006+A11+A1+A12+A2
		EN 60825-1:2014
		EN 60825-2:2004+A1+A2
UL	E317337	UL 60950-1
		CSA C22.2 No. 60950-1-07
EMC CE	AE 50285865 0001	EN 55022:2010
		EN 55024:2010
FCC	WTF14F0514417E	47 CFR PART 15 OCT., 2013
FDA	/	CDRH 1040.10
ROHS	/	2011/65/EU

Note2: The above certificate number updated to June 2014, because some certificate will be updated every year, such as FDA and ROHS. For the latest certification information, please check with Carelink.



RoHS compliant
Small Form Pluggable (SFP+)
SFP+ CWDM 70KM Optical Transceivers

Product Description

The CL-SFP+23C-L2-XX series optical transceiver is designed for fiber communications application such as 10G Ethernet (10GBASE-ZR/ZW), which fully compliant with the specification of SFP+ MSA SFF-8431.

This module is designed for single mode fiber and operates at a nominal wavelength of CWDM wavelength. There are ten center wavelengths available from 1470nm to 1610nm, with each step 20nm. A guaranteed optical link budget of 23 dB is offered.

The module is with the SFP+ connector to allow hot plug capability. Only single 3.3V power supply is needed. The optical output can be disabled by LVTTL logic high-level input of TX_DIS. Loss of signal (RX_LOS) output is provided to indicate the loss of an input optical signal of receiver.

This module provides digital diagnostic functions via a 2-wire serial interfaces defined by the SFF-8472 specification.

Absolute Maximum Ratings

Parameter	Symbol	Min	Typical	Max	Unit	Note
Maximum Supply Voltage 1	Vcc	-0.5		4.0	V	
Storage Temperature	T _s	-40		85	°C	

Recommend Operating Condition

Parameter	Symbol	Min	Typical	Max	Units
Case Operating Temperature	Standard	-5		+70	°C
	Extended	-20		+75	
Supply Voltage	Vcc	3.13	3.3	3.45	V
Supply Current	Icc			455	mA
Data Rate	EOLP-1696-23XN	0.6		11.3	Gbps

Electrical Characteristics

Parameter	Symbol	Min.	Typ.	Max	Unit	Notes
Transmitter						
CML Inputs(Differential)	V _{in}	180		1000	mVpp	1
Input Impedance (Differential)	Z _{in}	85	100	115	ohm	
TX_DISABLE Input Voltage – High		2		Vcc+0.3	V	
TX_DISABLE Input Voltage – Low		0		0.8	V	



RoHS compliant
Small Form Pluggable (SFP+)
SFP+ CWDM 70KM Optical Transceivers

TX_FAULT Output Voltage – High		2		V _{cc} +0.3	V	
TX_FAULT Output Voltage – Low		0		0.8	V	
Receiver						
CML Outputs (Differential)	V _{out}	350		700	mV _{pp}	1
Output Impedance (Differential)	Z _{out}	85	100	115	ohm	
RX_LOS Output Voltage – High		2		V _{cc} +0.3	V	
RX_LOS Output Voltage – Low		0		0.8	V	
MOD_DEF (0:2)	VoH	2.5			V	2
	VoL	0		0.5	V	

1. After internal AC coupling.
2. Reference the SFF-8472 MSA.

Optical Characteristics

Parameter	Symbol	Min	Typical	Max	Unit	Note
Transmitter						
Output Opt. Pwr: 9/125 SMF	P _{out}	0		4	dBm	1
Extinction Ratio EOLP-1696-23XN	ER	3.5			dB	
Optical Wavelength	λ	$\lambda_c - 6$	λ_c	$\lambda_c + 7.5$	nm	2
-20dB Spectrum Width	$\Delta\lambda$			1	nm	
Side Mode Suppression Ratio	SMSR	30			dB	
Average Launch Power of OFF Transmitter	P _{OFF}			-30	dBm	
Transmitter Dispersion Penalty	TDP			3.5	dB	
TX Jitter	TX _j	Per 802.3ae requirements				
Relative Intensity Noise	RIN			-128	dB/Hz	
Receiver						
Receiver Sensitivity	P _{min}			-23	dBm	3
Input Overload	P _{max}	-8			dBm	
Optical Center Wavelength	λ	1260		1620	nm	
Receiver Reflectance	R _{rf}			-12	dB	
LOS De-Assert	LOS _D			-24	dBm	
LOS Assert	LOS _A	-37			dBm	
LOS Hysteresis		1			dB	

1. Output power is coupled into a 9/125 μ m SMF.
2. ITU-T G.694.2 CWDM wavelength from 1470nm to 1610nm, each step 20nm.
3. Average received power; BER less than 1E-12 and PRBS 2₃₁-1 test pattern.



RoHS compliant
 Small Form Pluggable (SFP+)
 SFP+ CWDM 70KM Optical Transceivers

SFP+ Transceiver Electrical Pad Layout

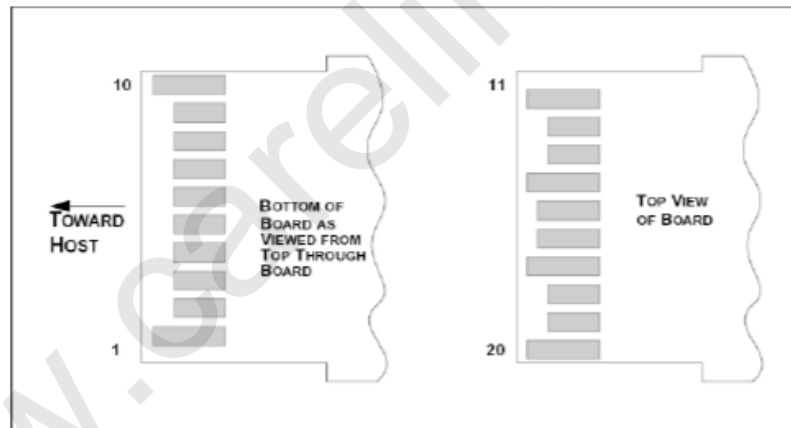
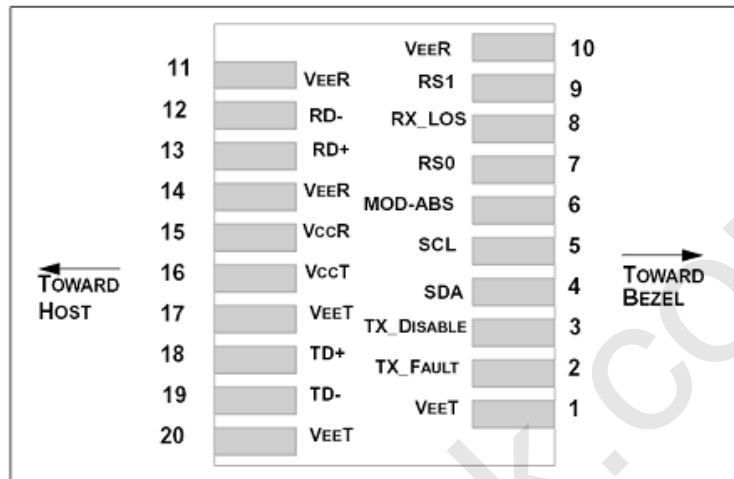

Pin Function Definitions

Pin Num.	Name	Function	Plug Seq.	Notes
1	VeeT	Transmitter Ground	1	Note 5
2	TX Fault	Transmitter Fault Indication	3	Note 1
3	TX Disable	Transmitter Disable	3	Note 2, Module disables on high or open



RoHS compliant
Small Form Pluggable (SFP+)
SFP+ CWDM 70KM Optical Transceivers

4	SDA	Module Definition 2	3	2-wire Serial Interface Data Line.
5	SCL	Module Definition 1	3	2-wire Serial Interface Clock.
6	MOD-ABS	Module Definition 0	3	Note 3
7	RS0	RX Rate Select (LVTTTL).	3	No Function Implement..
8	LOS	Loss of Signal	3	Note 4
9	RS1	TX Rate Select (LVTTTL).	1	No Function Implement..
10	VeeR	Receiver Ground	1	Note 5
11	VeeR	Receiver Ground	1	Note 5
12	RD-	Inv. Received Data Out	3	Note 6
13	RD+	Received Data Out	3	Note 6
14	VeeR	Receiver Ground	1	Note 5
15	VccR	Receiver Power	2	3.3V ± 5%, Note 7
16	VccT	Transmitter Power	2	3.3V ± 5%, Note 7
17	VeeT	Transmitter Ground	1	Note 5
18	TD+	Transmit Data In	3	Note 8
19	TD-	Inv. Transmit Data In	3	Note 8
20	VeeT	Transmitter Ground	1	Note 5

- 1) TX Fault is an open collector/drain output, which should be pulled up with a 4.7K – 10KΩ resistor on the host board. Pull up voltage between 2.0V and VccT/R+0.3V. When high, output indicates a laser fault of some kind. Low indicates normal operation. In the low state, the output will be pulled to < 0.8V.
- 2) TX disable is an input that is used to shut down the transmitter optical output. It is pulled up within the module with a 4.7K~10 K Ω resistor. Its states are:
 Low (0 – 0.8V): Transmitter on
 (>0.8, < 2.0V): Undefined
 High (2.0 – 3.465V): Transmitter Disabled
 Open: Transmitter Disabled
- 3) Module Absent, connected to VeeT or VeeR in the module.
- 4) LOS (Loss of Signal) is an open collector/drain output, which should be pulled up with a 4.7K – 10KΩ resistor on host board. Pull up voltage between 2.0V and VccT/R+0.3V. When high, this output indicates the received optical power is below the worst-case receiver sensitivity (as defined by the standard in use). Low indicates normal operation. In the low state, the output will be pulled to < 0.8V.
- 5) The module signal ground contacts, VeeR and VeeT, should be isolated from the module case.
- 6) RD-/+ : These are the differential receiver outputs. They are AC coupled 100Ω differential lines which should be terminated with 100Ω (differential) at the user SERDES. The AC coupling is done inside the module and is thus not required on the host board. The voltage swing on these lines will be between 370 and 700 Mv differential (185 –350Mv single ended) when properly terminated.
- 7) VccR and VccT are the receiver and transmitter power supplies. They are defined as 3.3V ±5% at the SFP+ connector pin. Maximum supply current is 300mA. Recommended host board power supply filtering is shown below. Inductors with DC resistance of less than 1 ohm should be used in order to maintain the required voltage at the SFP+ input pin with 3.3V supply voltage. When the recommended supply-filtering network is used, hot plugging of the SFP+ transceiver module will result in an inrush current of no more than



RoHS compliant
Small Form Pluggable (SFP+)
SFP+ CWDM 70KM Optical Transceivers

30Ma greater than the steady state value. VccR and VccT may be internally connected within the SFP+ transceiver module.

8) TD-/+: These are the differential transmitter inputs. They are AC-coupled, differential lines with 100Ω differential termination inside the module. The AC coupling is done inside the module and is thus not required on the host board.

AT24C02/04 family of components. When the serial protocol is activated, the host generates the serial clock signal (SCL). The serial data signal (SDA) is bi-directional for serial data transfer. The host uses SDA in conjunction with SCL to mark the start and end of serial protocol activation. The memories are organized as a series of 8-bit data words that can be addressed individually or sequentially.

The Module provides diagnostic information about the present operating conditions. The transceiver generates this diagnostic data by digitization of internal analog signals. Calibration and alarm/warning threshold data is written during device manufacture. Received power monitoring, transmitted power monitoring, bias current monitoring, supply voltage monitoring and temperature monitoring all are implemented. If the module is defined as external calibrated, the diagnostic data are raw A/D values and must be converted to real world units using calibration constants stored in EEPROM locations 56 – 95 at wire serial bus address A2H. The digital diagnostic memory map specific data field define as following .For detail EEPROM information, please refer to the related document of SFF 8472 Rev 10.3.

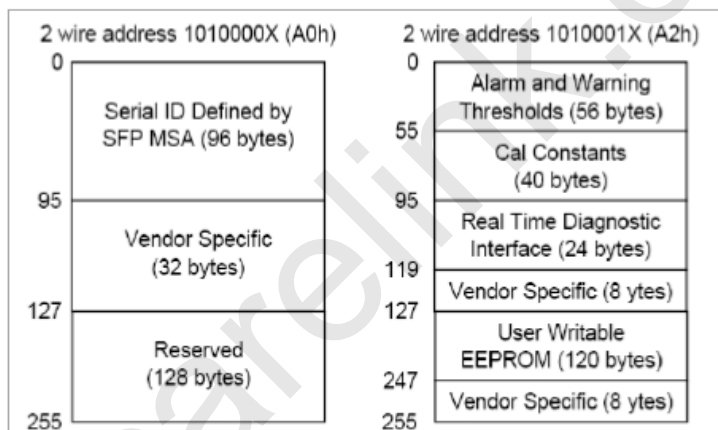

Recommend Circuit Schematic

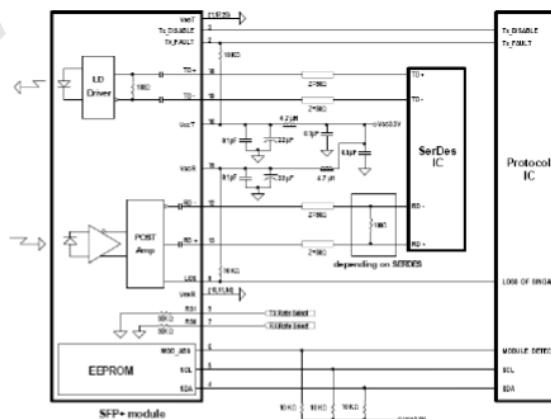



RoHS compliant
Small Form Pluggable (SFP+)
SFP+ CWDM 70KM Optical Transceivers

Mechanical Specifications

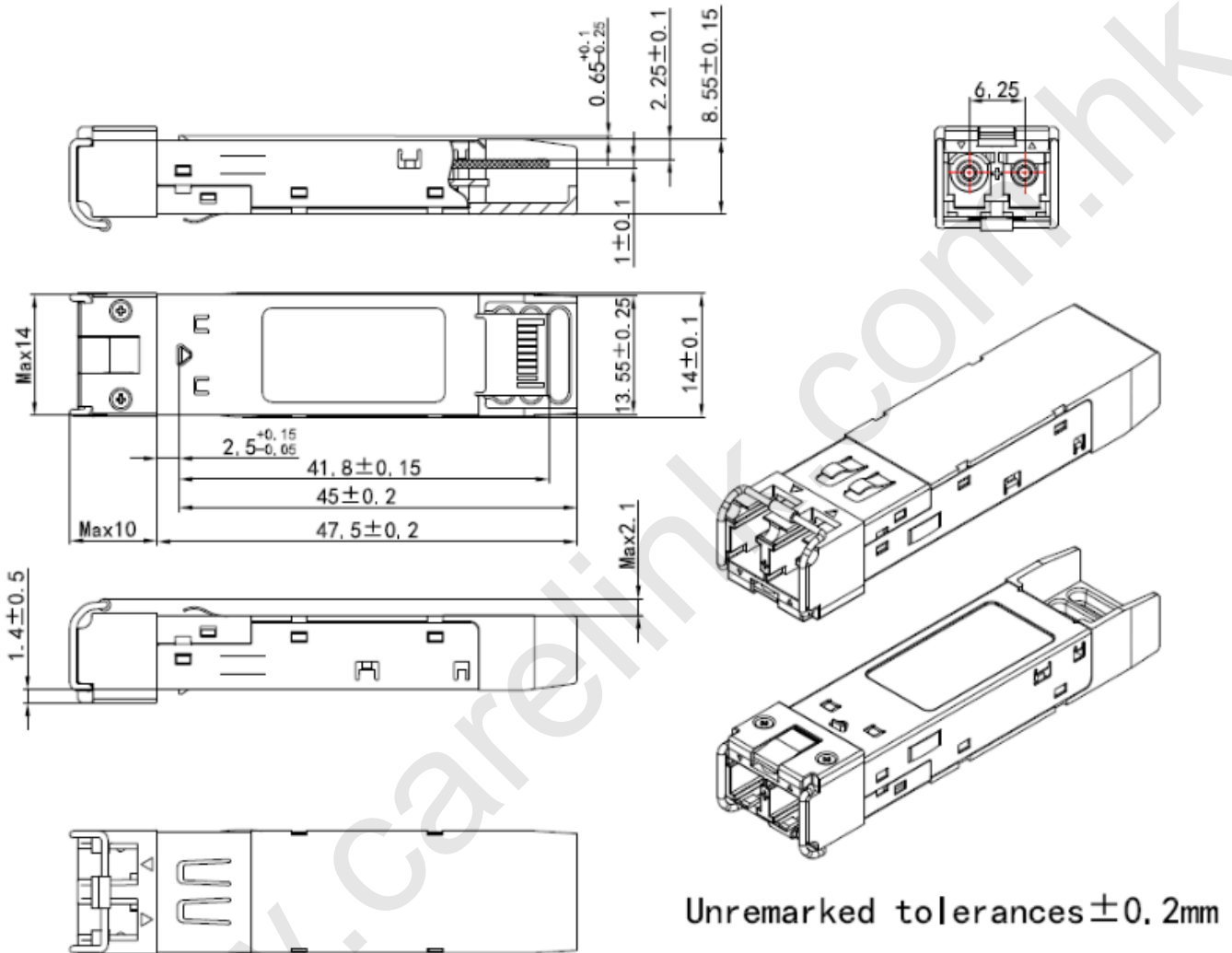

*This 2D drawing only for reference, please check with Carelink before ordering.

Eye Safety

This single-mode transceiver is a Class 1 laser product. It complies with IEC-60825 and FDA 21 CFR 1040.10 and 1040.11. The transceiver must be operated within the specified temperature and voltage limits. The optical ports of the module shall be terminated with an optical connector

Carelink reserves the right to make changes or discontinue any optical link product or service identified in this publications, without notice, in order to improve design and/or performance. Applications that are described herein for any of the optical link products are for illustrative purposes only. Carelink make no representations or warranty that such applications will be suitable for the specified use without further testing or modifications.