

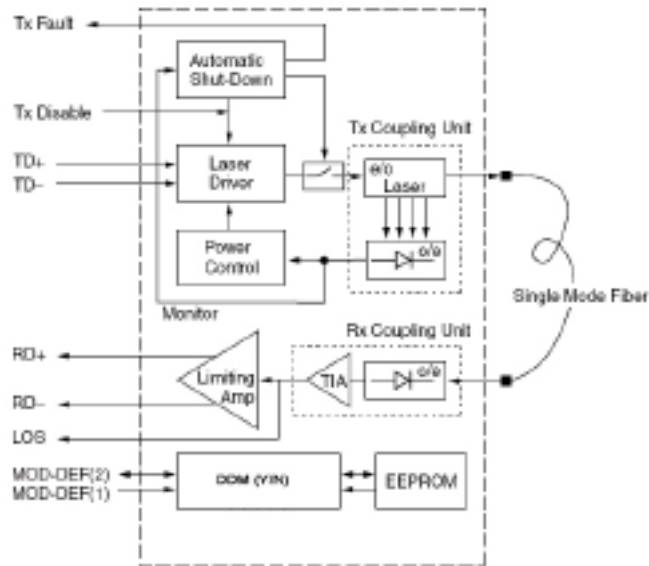

**RoHS compliant
Single-Mode CWDM up to 2.67Gbps
Duplex SFP Transceiver**

Functional Description of Transceiver



SFP Transceiver Electrical Pad Layout

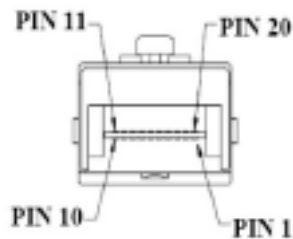
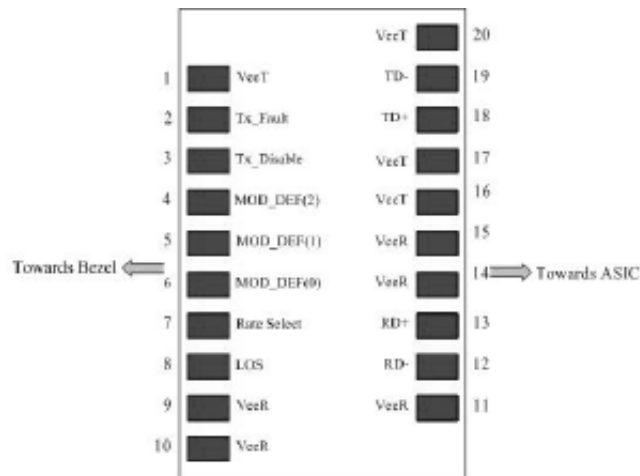



**RoHS compliant
Single-Mode CWDM up to 2.67Gbps
Duplex SFP Transceiver**

Pin Function Definitions

Pin Num.	Name	Function	Plug Seq.	Notes
1	VeeT	Transmitter Ground	1	5)
2	TX Fault	Transmitter Fault Indication	3	1)
3	TX Disable	Transmitter Disable	3	2) Module disables on high or open
4	MOD-DEF2	Module Definition 2	3	3) Data line for Serial ID.
5	MOD-DEF1	Module Definition 1	3	3) Clock line for Serial ID.
6	MOD-DEF0	Module Definition 0	3	3) Grounded within the module.
7	Rate Select	Not Connect	3	Function not available
8	LOS	Loss of Signal	3	4)
9	VeeR	Receiver Ground	1	5)
10	VeeR	Receiver Ground	1	5)
11	VeeR	Receiver Ground	1	5)
12	RD-	Inv. Received Data	3	6)
13	RD+	Received Data Out	3	6)
14	VeeR	Receiver Ground	1	5)
15	VccR	Receiver Power	2	7) 3.3 ± 5%
16	VccT	Transmitter Power	2	7) 3.3 ± 5%
17	VeeT	Transmitter Ground	1	5)
18	TD+	Transmit Data In	3	8)
19	TD-	Inv. Transmit Data	3	8)
20	VeeT	Transmitter Ground	1	5)

Notes:

- 1) TX Fault is an open collector/drain output, which should be pulled up with a 4.7K – 10K_Ω resistor on the host board. Pull up voltage between 2.0V and VccT, R+0.3V. When high, output indicates a laser fault of some kind. Low indicates normal operation. In the low state, the output will be pulled to < 0.8V.
- 2) TX disable is an input that is used to shut down the transmitter optical output. It is pulled up within the module with a 4.7 – 10 K_Ω resistor. Its states are:
 Low (0 – 0.8V): Transmitter on
 (>0.8, < 2.0V): Undefined
 High (2.0 – 3.465V): Transmitter Disabled
 Open: Transmitter Disabled
- 3) Mod-Def 0,1,2. These are the module definition pins. They should be pulled up with a 4.7K – 10K_Ω resistor on the host board. The pull-up voltage shall be VccT or VccR .
 Mod-Def 0 is grounded by the module to indicate that the module is present



RoHS compliant
Single-Mode CWDM up to 2.67Gbps
Duplex SFP Transceiver

Mod-Def 1 is the clock line of two wire serial interface for serial ID

Mod-Def 2 is the data line of two wire serial interface for serial ID

4) LOS (Loss of Signal) is an open collector/drain output, which should be pulled up with a 4.7K – 10K_Ω resistor. Pull up voltage between 2.0V and VccT, R+0.3V. When high, this output indicates the received optical power is below the worst-case receiver sensitivity (as defined by the standard in use). Low indicates normal operation. In the low state, the output will be pulled to < 0.8V.

5) VeeR and VeeT may be internally connected within the SFP module.

6) RD-/+ : These are the differential receiver outputs. They are AC coupled 100_Ω differential lines which should be terminated with 100_Ω (differential) at the user SERDES. The AC coupling is done inside the module and is thus not required on the host board. The voltage swing on these lines will be between 400 and 2000 Mv differential (200 – 1000 Mv single ended) when properly terminated.

7) VccR and VccT are the receiver and transmitter power supplies. They are defined as 3.3V ±5% at the SFP connector pin. Maximum supply current is 300Ma. Recommended host board power supply filtering is shown below. Inductors with DC resistance of less than 1 ohm should be used in order to maintain the required voltage at the SFP input pin with 3.3V supply voltage. When the recommended supply-filtering network is used, hot plugging of the SFP transceiver module will result in an inrush current of no more than 30Ma greater than the steady state value. VccR and VccT may be internally connected within the SFP transceiver module.

8) TD-/+ : These are the differential transmitter inputs. They are AC-coupled, differential lines with 100_Ω differential termination inside the module. The AC coupling is done inside the module and is thus not required on the host board. The inputs will accept differential swings of 400 – 2000Mv (200 – 1000Mv single-ended).

EEPROM:

The serial interface uses the 2-wire serial CMOS EEPROM protocol defined for the ATMEL AT24C02/04 family of components. When the serial protocol is activated, the host generates the serial clock signal (SCL). The positive edge clocks data into those segments of the EEPROM that are not writing protected within the SFP transceiver. The negative edge clocks data from the SFP transceiver. The serial data signal (SDA) is bi-directional for serial data transfer. The host uses SDA in conjunction with SCL to mark the start and end of serial protocol activation. The memories are organized as a series of 8-bit data words that can be addressed individually or sequentially.

The Module provides diagnostic information about the present operating conditions. The transceiver generates this diagnostic data by digitization of internal analog signals. Calibration and alarm/warning threshold data is written during device manufacture. Received power monitoring, transmitted power monitoring, bias current monitoring, supply voltage monitoring and temperature monitoring all are implemented. If the module is defined as external calibrated, the diagnostic data are raw A/D values and must be converted to real world units using calibration constants stored in EEPROM locations 56 – 95 at wire serial bus address A2H. The digital diagnostic memory map specific data field define as following .For detail EEPROM information, please refer to the related document of SFF 8472 Rev 9.3.

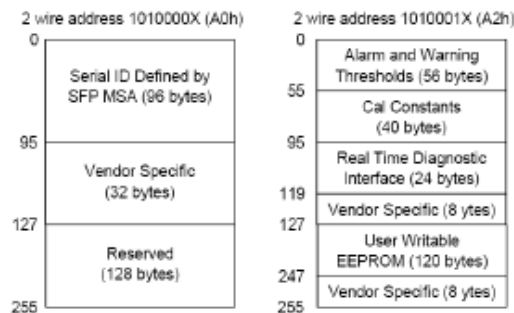



**RoHS compliant
Single-Mode CWDM up to 2.67Gbps
Duplex SFP Transceiver**

EEPROM Serial ID Memory Contents

Accessing Serial ID Memory uses the 2 wire address 1010000X(A0). Memory Contents of Serial ID are shown in Table 1.

Table 1 Serial ID Memory Contents

Addr.	Size (Bytes)	Name of Field	Hex	Description
BASE ID FIELDS				
0	1	Identifier	03	SFP
1	1	Ext. Identifier	04	SFP function is defined by serial ID only
2	1	Connector	07	LC Connector
3-10	8	Transceiver	XX	Transmitter Code
11	1	Encoding	03	NRZ
12	1	BR, Nominal	XX ^(Note11)	
13	1	Reserved	00	
14	1	Length (9μm)km	XX	Transceiver transmit distance
15	1	Length(9μm)100m	00	
16	1	Length (50μm) 10m	00	
17	1	Length(62.5μm)10m	00	
18	1	Length (Copper)	00	Not compliant
19	1	Reserved	00	
20-35	16	Vendor name	XX XX XX XX XX XX XX XX XX XX XX XX XX XX XX XX ^(Note11)	Vendor name (ASCII)
36	1	Reserved	00	
37-39	3	Vendor OUI	XX XX XX ^(Note11)	
40-55	16	Vendor PN		Transceiver part number
56-59	4	Vendor rev	XX XX XX XX ^(Note11)	
60-61	2	Wavelength	XX XX ^(Note11)	CWDM
62	1	Reserved	00	
63	1	CC_BASE	Check Sum (Variable)	Check code for Base ID Fields
EXTENDED ID FIELDS				
64-65	2	Options	00 1A	TX_DISABLE, TX_FAULT and Loss of Signal implemented.
66	1	BR,max	00	
67	1	BR,min	00	
68-83	16	Vendor SN	XX XX XX XX XX XX XX XX 20 20 20 20	Serial Number of transceiver (ASCII). For



**RoHS compliant
Single-Mode CWDM up to 2.67Gbps
Duplex SFP Transceiver**

			20 20 20 20 ^(Note11)	example "B000822".
84-91	8	Date code	XX XX XX XX XX XX XX XX ^(Note11)	Manufactory date code. For example "080405".
92	1	Diagnostic Monitoring Type	XX ^(Note11)	Digital diagnostic monitoring implemented
93	1	Enhanced Options	XX ^(Note11)	Optional flags
94	1	SFF_8472 Compliance	XX ^(Note11)	01 for diagnostics (Rev9.3 SFF-8472).
95	1	CC_EXT	Check Sum (Variable)	Check sum for Extended ID Field.
VENDOR SPECIFIC ID FIELDS				
96-127	32	Vendor Specific	Read only	Depends on customer information
128-255	128	Reserved	Read only	

Note11: The "xx" byte should be filled in according to practical case. For more information, please refer to the related document of SFP Multi-Source Agreement (MSA).

Recommend Circuit Schematic

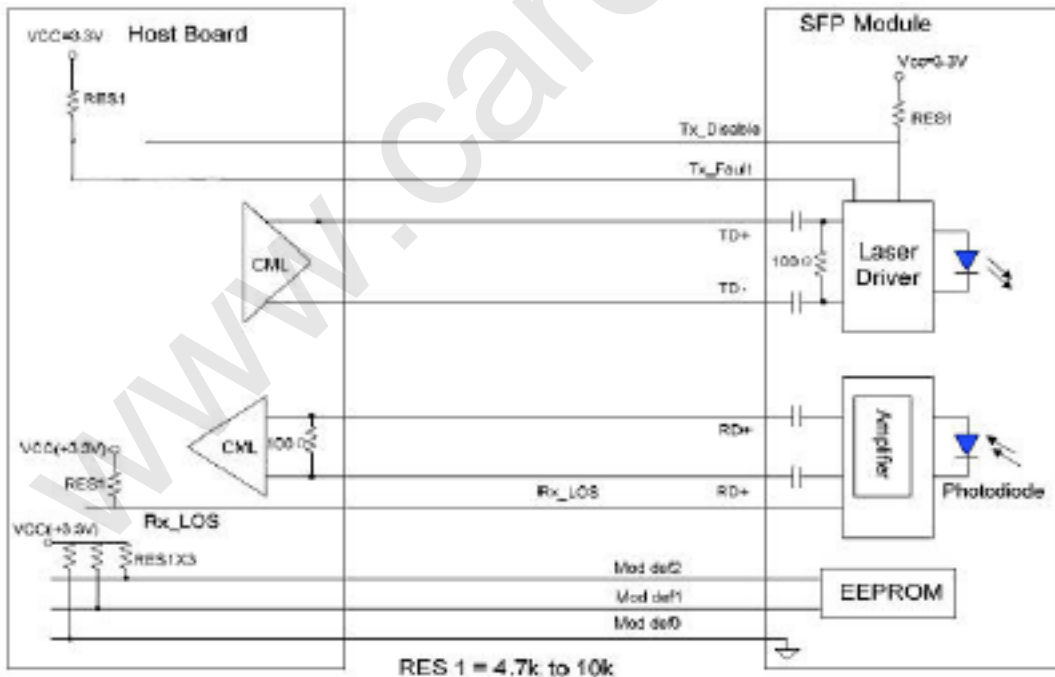



RoHS compliant
Single-Mode CWDM up to 2.67Gbps
Duplex SFP Transceiver

Mechanical Specifications

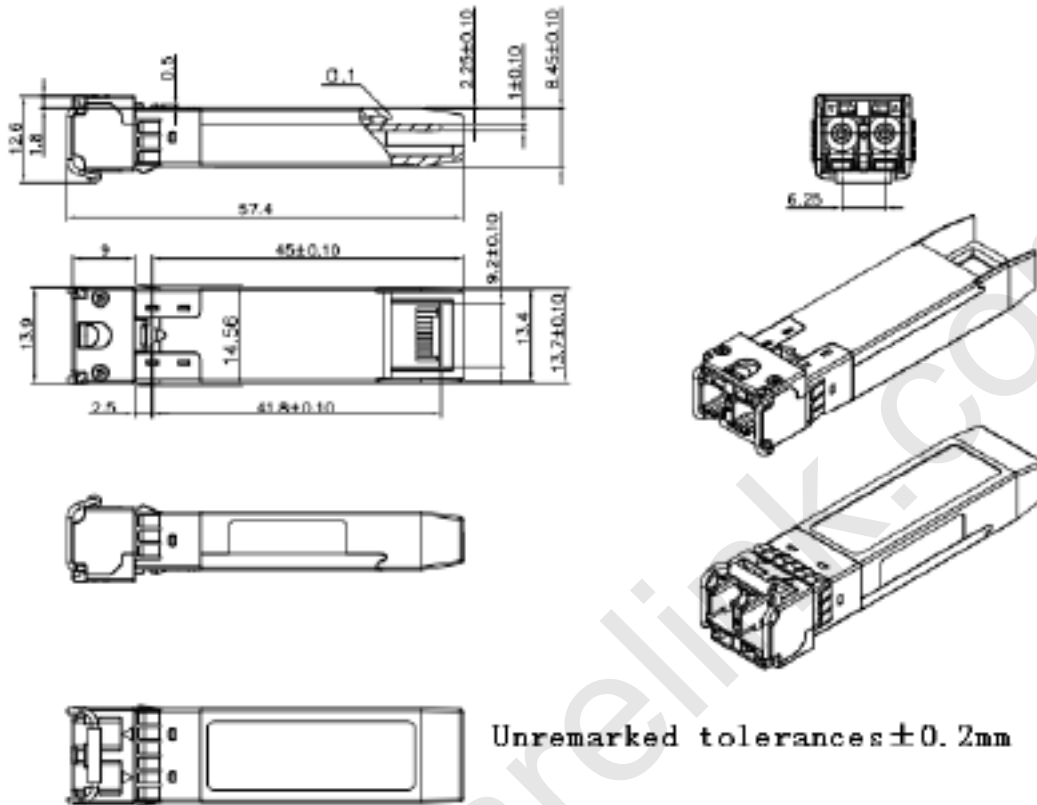

Laser Emission Data

Wavelength	>1260nm
Total output power (as defined by FDA: 7mm aperture at 20cm distance)	<0.79Mw
Total output power (as defined by IEC: 7mm aperture at 10cm distance)	<10Mw
Beam divergence	12.5°

Laser Emission

