



**CL-SFP28-WDM\_40-31**

**Tx: 1310nm/Rx: 1270nm BIDI SFP28 Transceiver for 25GbE/CPRI Option 10  
With DDM and Dual CDR, RoHS Compliant**



**Features:**

- Operating Data Rate Support 24.33Gbps and 25.78Gbps
- Two Types:
  - A: 1270nm Cooled DFB Transmitter / 1310nm APD Receiver
  - B: 1310nm Cooled DFB Transmitter / 1270nm APD Receiver
- Operating Case Temperature: Industrial: -40°C~+85°C
- Safety Certification: TUV/UL/FDA\*Note1
- RoHS Compliant
- Applications
  - CPRI Option 10 25GbE
    - Distance up to or 40km(ER)
    - Single 3.3V Power Supply
    - Power Dissipation < 1.8W
  - LC Connector Interface, Hot Pluggable
  - Built-in Dual CDR
  - Compliant with Specification SFF-8402
  - Build-in Digital Diagnostic Functions
- Operating Case Temperature:
  - Industrial: -40°C~+85°C
  - Safety Certification: TUV/UL/FDA\*Note1
- RoHS Compliant

**Applications**

- CPRI Option 10
- 25GbE
- 10GbE Optical Link

PART NUMBER	Monitor	INPUT/OUTPUT	SIGNAL DETECT	TEMPERATURE
CL-SFP28-WDM_40-31	X	AC/AC	TTL	-5°C to 70 °C
CL-SFP28-WDM_40-31i	X	AC/AC	TTL	-40°C to 85 °C



## CL-SFP28-WDM\_40-31

Tx: 1310nm/Rx: 1270nm BIDI SFP28 Transceiver for 25GbE/CPRI Option 10  
With DDM and Dual CDR, RoHS Compliant

### Product Description

The CL-SFP28-WDM\_40-31 optical transceiver is designed for fiber communications support 24.33Gbps and 25.78Gbps with CDR engaged, while, 10G Ethernet optical data communication can be supported when CDR is bypassed. It is with the SFP+ 20-pin connector to allow hot plug capability.

The CL-SFP28-WDM\_40-31 module is designed for single mode fiber and operates at a nominal wavelength of TX-1270nm/RX-1310nm. The CL-SFP28-WDM\_40-31 module is designed for single mode fiber and operates at a nominal wavelength of TX-1310nm/RX-1270nm. It can communicate over single mode fibers(SMF) of length up to 40km.

The transmitter section uses a multiple quantum well DFB, which is class 1 laser compliant according to International Safety Standard IEC-60825.

The receiver section uses an integrated InGaAs detector preamplifier (IDP) mounted in an optical header and a limiting post-amplifier IC.

### Absolute Maximum Ratings<sup>\*Note3</sup>

Parameter	Symbol	Min.	Max.	Unit
Storage Temperature	T <sub>s</sub>	-40	+85	°C
Supply Voltage	V <sub>CC</sub>	-0.5	+4.0	V
Operating Relative Humidity <sup>*Note4</sup>	RH	0	85	%

Note3: Exceeding any one of these values may destroy the device permanently.

Note4: Non-Condensing.

### Recommended Operating Conditions

Parameter	Symbol	Min.	Typical	Max.	Unit
Operating Case Temperature	T <sub>c</sub>	-40		85	°C
Power Supply Voltage	V <sub>CC</sub>	3.135		3.465	V
Power Supply Current	I <sub>CC</sub>			520	mA

### Performance Specifications – Electrical

Parameter	Symbol	Min.	Typ.	Max	Unit	Notes
<b>Transmitter</b>						
CML Inputs (Differential)	V <sub>in</sub>	200		900	mVpp	AC coupled inputs
Input Impedance (Differential)	Z <sub>in</sub>		100		ohms	Connected directly to TX pins
Tx_DISABLE Input Voltage – High		2		V <sub>CC</sub> +0.3	V	



CL-SFP28-WDM\_40-31

Tx: 1310nm/Rx: 1270nm BIDI SFP28 Transceiver for 25GbE/CPRI Option 10  
With DDM and Dual CDR, RoHS Compliant

Tx_DISABLE Input Voltage – Low		-0.3		0.8	V	
<b>Receiver</b>						
CML Outputs (Differential)	Vout	300		1000	mVpp	AC coupled outputs
Rx_LOS Output Voltage – High		2.4		Vcc+0.3	V	
Rx_LOS Output Voltage – Low		-0.3		0.8	V	

## Optical and Electrical Characteristics

(1310nm Cooled DFB & 1270nm APD/TIA)

Parameter	Symbol	Min.	Typ.	Max.	Unit
Transmission Distance@9um Core Diameter SMF	CL-SFP28-WDM_40-33			40	Km
Data Rate	DR			25.78	Gbps
<b>Transmitter</b>					
Optical Center Wavelength	$\lambda$	1300	1310	1320	nm
Spectral Width (-20dB)	$\Delta\lambda$			1	nm
Side Mode Suppression Ratio	SMSR	30			dB
Average Output Power @25.78Gbps	P <sub>AVG</sub>	-1		+6.0	dBm
Optical Modulation Amplitude(OMA)	P <sub>OMA</sub>	0		6	dBm
ER		4.0			dB
Transmitter Dispersion Penalty	TDP			2.7	dB
OMA minus TDP		-1			dBm
Transmitter Reflectance				-26	dB
Return Loss tolerance				20	dB
Relative Intensity Noise	RIN			-130	dB/Hz
Average Launch Power of OFF Transmitter	P <sub>OFF</sub>			-30	dBm
Transmitter Eye Mask Definition {X1, X2, X3, Y1, Y2, Y3} Hit Ratio 5E-5 Hits per Sample				{0.31,0.40,0.45,0.34,0.38,0.4}	
<b>Receiver</b>					



**CL-SFP28-WDM\_40-31**

**Tx: 1310nm/Rx: 1270nm BIDI SFP28 Transceiver for 25GbE/CPRI Option 10  
With DDM and Dual CDR, RoHS Compliant**

Center Wavelength	$\lambda_c$	1260		1280	nm
Average Receive Power	$R_{pow}$	-21		-4	dBm
Receiver Sensitivity* <sup>Note8</sup> CL-SFP28-WDM_40-31	$P_{min}$			-19	dBm
Receiver Sensitivity(OMA)* <sup>Note8</sup> CL-SFP28-WDM_40-31	$P_{min}$			-16.0	dBm
Receiver Sensitivity(OMA)* <sup>Note8</sup> CL-SFP28-WDM_40-31	$P_{min}$			-19.0	dBm
Stressed Receiver Sensitivity* <sup>Note8</sup> CL-SFP28-WDM_40-31	$R_{XSRS}$			-16.5	dBm
Receiver Overload* <sup>Note9</sup>	$P_{max}$	-4			dBm
Receiver Overload(OMA)* <sup>Note9</sup>	$P_{max}$	-4			dBm
Damage threshold		3			dBm
Receiver Reflectance				-26	dB
LOS De-Assert	$LOS_D$			-23	dBm
LOS Assert	$LOS_A$	-35			dBm
LOS Hysteresis	HY	0.5			dB

Note8: Measured with data rate at 25.78Gbps, BER less than 5E-5 with PRBS 231-1. For The CL-SFP28-WDM\_40-33, Link attenuation needs to be less than the worst case specified for IEC 60793-2-50 type B1.1, type B1.3, or type B6\_a single-mode fiber.

Note9: The CL-SFP28-WDM\_40-33 is targeted for long reach application with high power transmitter. Please ensure at least 10dB optical attenuation for optical loopback test.

www.Linkare.com



CL-SFP28-WDM\_40-31

Tx: 1310nm/Rx: 1270nm BIDI SFP28 Transceiver for 25GbE/CPRI Option 10  
With DDM and Dual CDR, RoHS Compliant

## SFP28 Transceiver Electrical Pad Layout

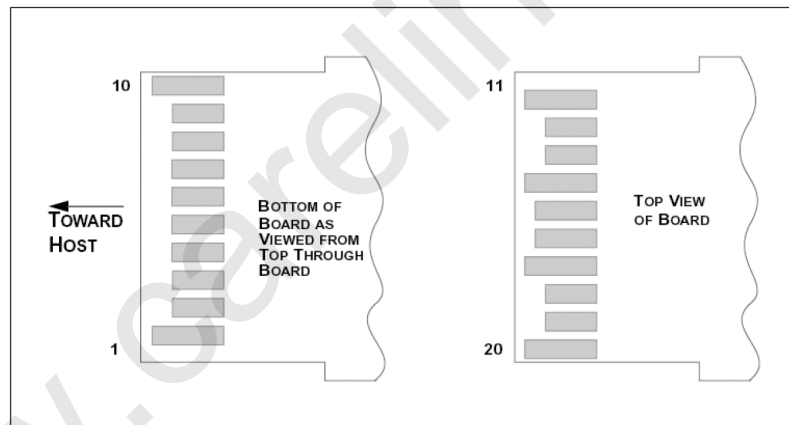
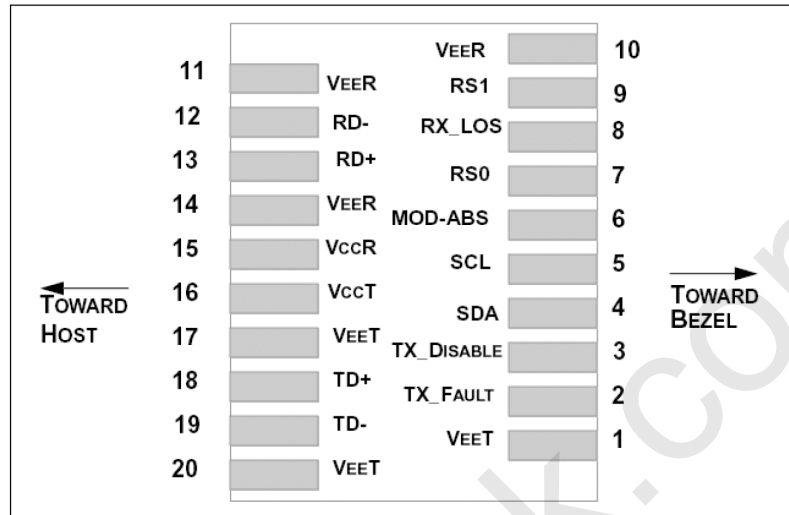

## Pin Function Definitions

Pin Num.	Name	Function	Plug Seq.	Notes
1	VeeT	Transmitter Ground	1	Note 5)
2	TX Fault	Transmitter Fault Indication	3	Note 1)
3	TX Disable	Transmitter Disable	3	Note 2), Module disables on high or open
4	SDA	Module Definition 2	3	Data line for Serial ID.
5	SCL	Module Definition 1	3	Clock line for Serial ID.



**CL-SFP28-WDM\_40-31**

**Tx: 1310nm/Rx: 1270nm BIDI SFP28 Transceiver for 25GbE/CPRI Option 10  
With DDM and Dual CDR, RoHS Compliant**

6	MOD-ABS	Module Definition 0	3	Note 3)
7	RS0	RX Rate Select (LVTTTL).	3	Rate Select 0, optionally controls SFP28 module receiver. This pin is pulled low to VeeT with a >30K resistor.
8	RX LOS	Loss of Signal	3	Note 4)
9	RS1	TX Rate Select (LVTTTL).	1	Rate Select 1, optionally controls SFP28 module transmitter. This pin is pulled low to VeeT with a >30K resistor.
10	VeeR	Receiver Ground	1	Note 5)
11	VeeR	Receiver Ground	1	Note 5)
12	RD-	Inv. Received Data Out	3	Note 6)
13	RD+	Received Data Out	3	Note 6)
14	VeeR	Receiver Ground	1	Note 5)
15	VccR	Receiver Power	2	3.3V ± 5%, Note 7)
16	VccT	Transmitter Power	2	3.3V ± 5%, Note 7)
17	VeeT	Transmitter Ground	1	Note 5)
18	TD+	Transmit Data In	3	Note 8)
19	TD-	Inv. Transmit Data In	3	Note 8)
20	VeeT	Transmitter Ground	1	Note 5)

**Notes:**

Note 1) TX Fault is an open collector/drain output, which should be pulled up with a 4.7K – 10KΩ resistor on the host board. Pull up voltage between 2.4V and VccT/R+0.3V. When high, output indicates a laser fault of some kind. Low indicates normal operation. In the low state, the output will be pulled to < 0.4V.

Note 2) TX disable is an input that is used to shut down the transmitter optical output. It is pulled up within the module with a 4.7K~10 K Ω resistor. Its states are:

Low (-0.3 – 0.8V): Transmitter on

(>0.8, < 2.0V): Undefined

High (2.0 – VccT/R+0.3V): Transmitter Disabled

Open: Transmitter Disabled

Note 3) Module Absent, connected to VeeT or VeeR in the module.

Note 4) RX LOS (Loss of Signal) is an open collector/drain output, which should be pulled up with a 4.7K – 10KΩ resistor. Pull up voltage between 2.4V and VccT/R+0.3V. When high, this output indicates the received optical power is below the worst-case receiver sensitivity (as defined by the standard in use). Low indicates normal operation. In the low state, the output will be pulled to < 0.4V.

Note 5) VeeR and VeeT may be internally connected within the SFP28 module.

Note 6) RD-/+ : These are the differential receiver outputs. They are AC coupled 100Ω differential lines which should be terminated with 100Ω (differential) at the user SERDES. The AC coupling is done inside the module and is thus not required on the host board. The voltage swing on these lines will be between 150mV and 500mV single-ended when properly terminated.



**CL-SFP28-WDM\_40-31**

**Tx: 1310nm/Rx: 1270nm BIDI SFP28 Transceiver for 25GbE/CPRI Option 10  
With DDM and Dual CDR, RoHS Compliant**

Note 7) VccR and VccT are the receiver and transmitter power supplies. They are defined as 3.3V ±5% at the SFP+ connector pin. Maximum supply current is 455mA. Inductors with DC resistance of less than 1 ohm should be used in order to maintain the required voltage at the SFP28 input pin with 3.3V supply voltage. When the recommended supply-filtering network is used, hot plugging of the SFP28 transceiver module will result in an inrush current of no more than 30mA greater than the steady state value. VccR and VccT may be internally connected within the SFP28 transceiver module.

Note 8) TD-/+ : These are the differential transmitter inputs. They are AC-coupled, differential lines with 100Ω differential termination inside the module. The AC coupling is done inside the module and is thus not required on the host board. The inputs will accept swings less than 450mV single-ended, though it is recommended that values between 90mV-900mV in differential be used for best EMI performance.

**EEPROM**

The serial interface uses the 2-wire serial CMOS EEPROM protocol. When the serial protocol is activated, the host generates the serial clock signal (SCL). The positive edge clocks data into those segments of the EEPROM that are not writing protected within the SFP28 transceiver. The negative edge clocks data from the SFP28 transceiver. The serial data signal (SDA) is bi-directional for serial data transfer. The host uses SDA in conjunction with SCL to mark the start and end of serial protocol activation. The memories are organized as a series of 8-bit data words that can be addressed individually or sequentially.

The Module provides diagnostic information about the present operating conditions. The transceiver generates this diagnostic data by digitization of internal analog signals. Calibration and alarm/warning threshold data is written during device manufacture. Received power monitoring, transmitted power monitoring, bias current monitoring, supply voltage monitoring and temperature monitoring all are implemented. If the module is defined as external calibrated, the diagnostic data are raw A/D values and must be converted to real world units using calibration constants stored in EEPROM locations 56 – 95 at wire serial bus address A2H. The digital diagnostic memory map specific data field define as following. For detail EEPROM information, please refer to the related document of SFF 8472 Rev 12.2.

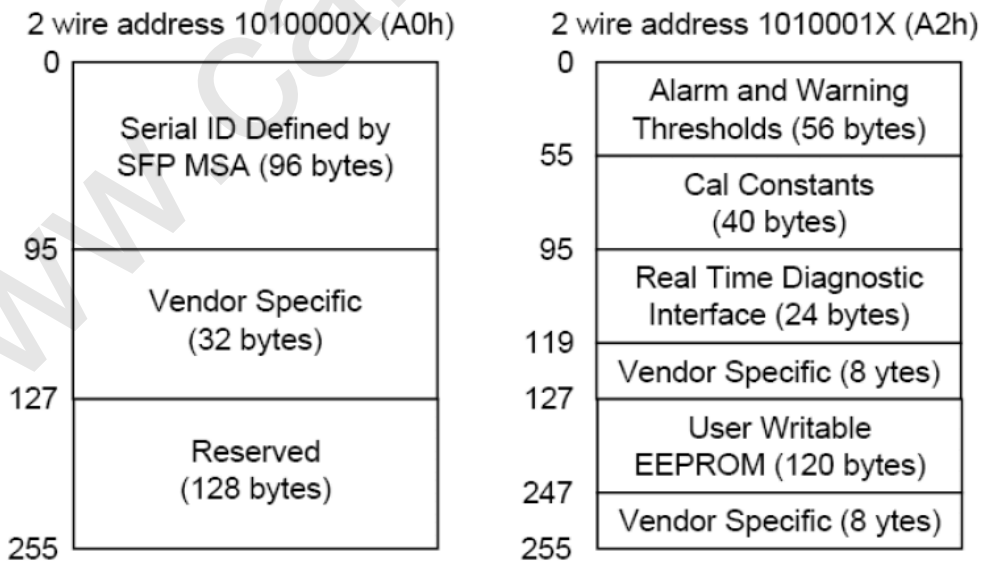



**CL-SFP28-WDM\_40-31**

**Tx: 1310nm/Rx: 1270nm BIDI SFP28 Transceiver for 25GbE/CPRI Option 10  
With DDM and Dual CDR, RoHS Compliant**

**Operations about Retimer/CDR Rate Select Logic**

The CL-SFP28-WDM\_40-31 supports high data rates 24.33G/25.78G (CPRI options 10 /25GbE) and Low data rates 9.95G/10.31G(10GbE). For more details, please contact Carelink.

Logic OR of RS0 Pin and Bit110.3 of A2H	Logic OR of RS1 Pin and Bit118.3 of A2H	RX Data Rate	TX Data Rate	Status of RX CDR	Status of TX CDR
High/1	High/1	24.33G/25.78G	24.33G/25.78G	CDR Engaged	CDR Engaged
High/1	Low/0	24.33G/25.78G	9.95G/10.31G	CDR Engaged	CDR Bypassed
Low/0	High/1	9.95G/10.31G	24.33G/25.78G	CDR Bypassed	CDR Engaged
Low/0	Low/0	9.95G/10.31G	9.95G/10.31G	CDR Bypassed	CDR Bypassed

**Mechanical Specifications**

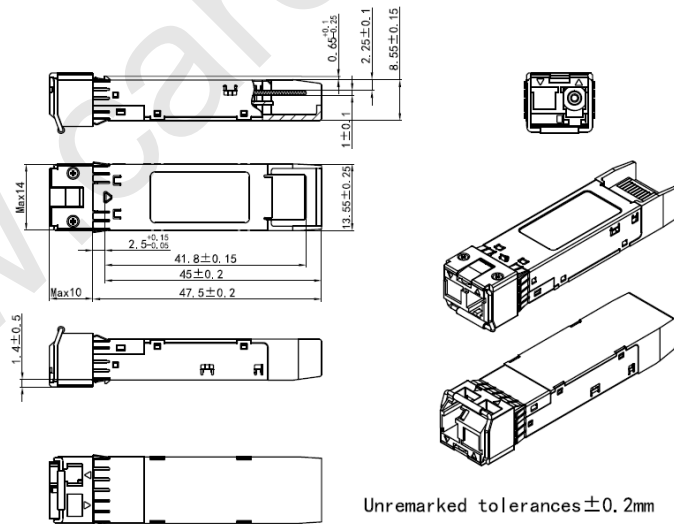

\*This 2D drawing only for reference, please check with Carelink before ordering.

**Eye Safety**

This single-mode transceiver is a Class 1 laser product. It complies with IEC-60825 and FDA 21 CFR 1040.10 and 1040.11. The transceiver must be operated within the specified temperature and voltage limits. The optical ports of the module shall be terminated with an optical connector or with a dust plug.





**CL-SFP28-WDM\_40-31**

**Tx: 1310nm/Rx: 1270nm BIDI SFP28 Transceiver for 25GbE/CPRI Option 10  
With DDM and Dual CDR, RoHS Compliant**

---

**Notice:**

Carelink reserves the right to make changes or discontinue any optical link product or service identified in this publication, without notice, in order to improve design and/or performance.

Applications that are described herein for any of the optical link products are for illustrative purposes only. Carelink makes no representation or warranty that such applications will be suitable for the specified use without further testing or modification.

[www.carelink.com.hk](http://www.carelink.com.hk)